

ENGINEERING DRAWING

(NSQF)

(As per Revised Syllabus July 2022)

Group 13

Plumber



Directorate General of Training

DIRECTORATE GENERAL OF TRAINING
MINISTRY OF SKILL DEVELOPMENT & ENTREPRENEURSHIP
GOVERNMENT OF INDIA



**NATIONAL INSTRUCTIONAL
MEDIA INSTITUTE, CHENNAI**

Post Box No. 3142, CTI Campus, Guindy, Chennai - 600 032

Engineering Drawing (NSQF) 1 Year
Group 13 Engineering Trades
As per Revised syllabus July 2022 under CTS

Developed & Published by



National Instructional Media Institute

Post Box No.3142
Guindy, Chennai - 600032
INDIA
Email: chennai-nimi@nic.in
Website: www.nimi.gov.in

Copyright © 2022 National Instructional Media Institute, Chennai

First Edition : September 2022

Copies : 1000

Rs.80/-

All rights reserved.

No part of this publication can be reproduced or transmitted in any form or by any means, electronic or mechanical, including photocopy, recording or any information storage and retrieval system, without permission in writing from the National Instructional Media Institute, Chennai.

FOREWORD

The Government of India has set an ambitious target of imparting skills to 30 crores people, one out of every four Indians, by 2020 to help them secure jobs as part of the National Skills Development Policy. Industrial Training Institutes (ITIs) play a vital role in this process especially in terms of providing skilled manpower. Keeping this in mind, and for providing the current industry relevant skill training to Trainees, ITI syllabus has been recently updated with the help of comprising various stakeholder's viz. Industries, Entrepreneurs, Academicians and representatives from ITIs.

The National Instructional Media Institute (NIMI), Chennai, has now come up with instructional material to suit the revised curriculum for **Engineering Drawing NSQF Group 13 Engineering Trades (Revised 2022)** under CTS will help the trainees to get an international equivalency standard where their skill proficiency and competency will be duly recognized across the globe and this will also increase the scope of recognition of prior learning. NSQF trainees will also get the opportunities to promote life long learning and skill development. I have no doubt that with NSQF the trainers and trainees of ITIs, and all stakeholders will derive maximum benefits from these IMPs and that NIMI's effort will go a long way in improving the quality of Vocational training in the country.

The Executive Director & Staff of NIMI and members of Media Development Committee deserve appreciation for their contribution in bringing out this publication.

Jai Hind

New Delhi - 110 001

SHRI. ATUL KUMAR TIWARI., I.A.S.,
Secretary
Ministry of Skill Development & Entrepreneurship,
Government of India.

PREFACE

The National Instructional Media Institute(NIMI) was set up at Chennai, by the Directorate General of Training, Ministry of skill Development and Entrepreneurship, Government of India, with the technical assistance from the Govt of the Federal Republic of Germany with the prime objective of developing and disseminating instructional Material for various trades as per prescribed syllabus and Craftsman Training Programme(CTS) under NSQF levels.

The Instructional materials are developed and produced in the form of Instructional Media Packages (IMPs), consisting of Trade Theory, Trade Practical, Test and Assignment Book, Instructor Guide, Wall charts, Transparencies and other supportive materials. The above material will enable to achieve overall improvement in the standard of training in ITIs.

A national multi-skill programme called SKILL INDIA, was launched by the Government of India, through a Gazette Notification from the Ministry of Finance (Dept of Economic Affairs), Govt of India, dated 27th December 2013, with a view to create opportunities, space and scope for the development of talents of Indian Youth, and to develop those sectors under Skill Development.

The emphasis is to skill the Youth in such a manner to enable them to get employment and also improve Entrepreneurship by providing training, support and guidance for all occupation that were of traditional types. The training programme would be in the lines of International level, so that youths of our Country can get employed within the Country or Overseas employment. The **National Skill Qualification Framework (NSQF)**, anchored at the National Skill Development Agency(NSDA), is a Nationally Integrated Education and competency-based framework, to organize all qualifications according to a series of **levels of Knowledge, Skill and Aptitude**. Under NSQF the learner can acquire the Certification for Competency needed at any level through formal, non-formal or informal learning.

The **Engineering Drawing** NSQF Group 13 - Engineering Trades (Revised 2022) under CTS is one of the book developed by the core group members as per the NSQF syllabus.

The **Engineering Drawing** NSQF Group 13 - Engineering Trades (Revised 2022) under CTS as per NSQF is the outcome of the collective efforts of experts from Field Institutes of DGT, Champion ITI's for each of the Sectors, and also Media Development Committee (**MDC**) members and Staff of **NIMI**. NIMI wishes that the above material will fulfill to satisfy the long needs of the trainees and instructors and shall help the trainees for their Employability in Vocational Training.

NIMI would like to take this opportunity to convey sincere thanks to all the Members and Media Development Committee (MDC) members.

Chennai - 600 032

EXECUTIVE DIRECTOR

ACKNOWLEDGEMENT

The National Instructional Media Institute (NIMI) sincerely acknowledge with thanks the co-operation and contribution of the following Media Developers to bring this IMP for the course **Engineering Drawing Group 13 - Engineering Trade** as per NSQF Revised 2022.

MEDIA DEVELOPMENT COMMITTEE MEMBERS

Shri. M. Sangara pandian	-	Training Officer (Retd.) CTI, Govt. of India, Guindy, Chennai - 32.
Shri. G. Sathiamoorthy	-	Jr. Training Officer - SG (Retd.) Govt. I.T.I., Trichy, DET - Tamilnadu.
Shri. D. Sundar	-	Assistant Training Officer, Govt. I.T.I., Ambattur, Chennai - 98.
Shri. R. Sundar	-	Assistant Training Officer, Govt. I.T.I., Karumandhurai, Salem.
Shri. C.C. Subramanian	-	Training Officer (Retd.) Balamandir PHMITI, Chennai - 17.

NIMI CO-ORDINATORS

Shri. Nirmalya Nath	-	Deputy General Manager, NIMI, Chennai - 32.
Shri. G. Michael Johny	-	Manager, NIMI, Chennai - 32.

NIMI records its appreciation of the **Data Entry, CAD, DTP Operators** for their excellent and devoted services in the process of development of this IMP.

NIMI also acknowledges with thanks, the efforts rendered by all other staff who have contributed for the development of this book.

INTRODUCTION

Theory and procedure along with the related exercises for further practice

This book on theory and procedure along with related exercises contains theoretical information on **1 Year Engineering drawing** NSQF (Revised syllabus July 2022 Group 13 - Engineering Trade) and procedure of drawing/sketching different exercise for further practice are also available. Wherever required, BIS specification has been used.

Exercise for further practice

The practice exercise is given with Theory and procedure for 1 Year book made obsolete as it was felt that, it is very difficult to work in workbook using drawing instruments. It is well known fact that, any drawing is prepared on suitable standard size of drawing sheets only.

The instructor is herewith advised to go through the instructions given below and to follow them in view of imparting much drawing skill in the trainees.

Acquiring the above said ability and doing small drawings is not a simple task. These books will provide a good platform for achieving the said skills.

Time allotment:

Duration of 1 Year : 40 Hrs

Sl. No.	Topic	Exercise No.	Time Allotment
1	Introduction to Engineering Drawing and Drawing Instruments	1.1.01 - 1.1.05	2
2	Free hand drawing	1.2.06 - 1.2.08	6
3	Drawing of Geometrical Figures	1.3.09 - 1.3.11	8
4	Reading of dimension and dimensioning practice	1.4.12 & 1.4.13	4
5	Symbolic Representation	1.5.14 & 1.5.15	10
6	Reading of Layout Plan drawing	1.6.16 & 1.6.17	10
			<hr/> 40 Hrs <hr/>

Instructions to the Instructors

It is suggested to get the drawing prepared on A4/A3 sheets preferably on only one side. If separate table and chair facility is available for every trainee then it is preferred to use A3 sheets and if the drawing hall is provided with desks then A4 sheets may be used. However while preparing bigger drawings on A4 sheets suitable reduction scale to be used or multiple sheets may be used for detailed and assembly drawings.

First the border and the title block to be drawn only for the first sheet of the chapter. Eg. for conical sections only first sheet will have the title block whereas the rest of the sheets of that chapter will have only borders.

Serial number of sheet and total no. of sheets to be mentioned on each sheet.

The completed sheet to be punched and filled in a box file/ suitable files and preserved by the trainees carefully after the approval of instructor, VP and Principal of the Institute.

The file may be referred by the authority before granting the internal marks at the end of the Year.

CONTENTS

Exercise No.	Topic of the Exercise	Page No.
	Introduction to Engineering Drawing and Drawing Instruments	
1.1.01	Introduction to engineering drawing and drawing instruments	1
1.1.02	Conventions	4
1.1.03	Sizes and layout of drawing sheets	5
1.1.04	Title block, its position and content	7
1.1.05	Drawing instruments	11
	Free hand drawing	
1.2.06	Free hand drawing of - Geometrical figures and blocks with dimension	16
1.2.07	Free hand drawing of - Transferring measurement from the given object to the free hand sketches	20
1.2.08	Free hand drawing of hand tools and measuring tools	24
	Drawing of Geometrical Figures	
1.3.09	Drawing of geometrical figures - Angle & triangle	29
1.3.10	Drawing of geometrical figures - Circle	32
1.3.11	Drawing of geometrical figures - Square, rectangle and parallelogram	34
	Reading of dimension and dimensioning practice	
1.4.12	Reading of dimension and dimensioning practice - Dimensioning	36
1.4.13	Practice of dimensioning	39
	Symbolic Representation	
1.5.14	Symbolic representation - Different symbols	42
1.5.15	Symbolic representation - Pipe joints used in the trade	44
	Reading of Layout Plan drawing	
1.6.16	Reading of layout plan drawing in piping - Pipe fittings	50
1.6.17	Reading of layout plan drawing in piping - Sanitary fittings	55

LEARNING / ASSESSABLE OUTCOME

On completion of this book you shall be able to

- **Read and apply engineering drawing for different application in the field of work.**

SYLLABUS

1 Year

Group 13 - Revised syllabus July 2022
Engineering trades under CTS

Duration: 1 Year

CTS Trades Covered: Plumber

S.no.	Syllabus	Time in Hrs
1	Introduction to Engineering Drawing and Drawing Instruments – <ul style="list-style-type: none">• Conventions• Sizes and layout of drawing sheets• Title Block, its position and content• Drawing Instruments	2
2	Free hand drawing of - <ul style="list-style-type: none">• Geometrical figures and blocks with dimension• Transferring measurement from the given object to the free hand sketches.• Free hand drawing of hand tools and measuring tools	6
3	Drawing of Geometrical figures: <ul style="list-style-type: none">• Angle, Triangle, Circle, Rectangle, Square, Parallelogram.	8
4	<ul style="list-style-type: none">• Reading of dimension and Dimensioning Practice.	4
5	Symbolic representation - <ul style="list-style-type: none">• Different symbols and Pipe joints used in the trade.	10
6	Reading of layout plan drawing in piping	10
	Total	40

Introduction to engineering drawing and drawing instruments

Communication

There are many different ways of communicating ideas, information, instructions, requests, etc. They can be transmitted by signs or gestures, by word of mouth, in writing, or graphically. In an industrial context the graphical method is commonly used with communication is achieved by means of engineering drawings.

If oral and written communication only were used when dealing with technical matters, misunderstandings could arise, particularly in relation to shape and size. The lack of a universal spoken language makes communication and understanding even more difficult because of the necessity to translate both words and meaning from one language to another.

However, the universally accepted methods used in graphical communication through engineering drawings eliminate many of these difficulties and make it possible for drawing prepared by a British designer to be correctly interpreted or "read" by, for example, his German, French or Dutch counterparts.

Equally important, the components shown on the drawings could be made by suitably skilled craftsmen of any nationality provided they can "read" an engineering drawing.

Conventionally prepared engineering drawings provide the main means of communication between the "ideas" men (the designers and draughtsman) and the craftsmen (machinists, fitters, assemblers, etc.). For the communication to be effective, everyone concerned must interpret the drawing in the same way. Only then will the finished product be exactly as the designer envisages it.

To ensure uniformity of interpretation, the British Standards Institution has prepared a booklet entitled BS 308:1972, Engineering Drawing Practice. Now in three parts, this publication recommends the methods which should be adopted for the preparation of drawing used in the engineering industry.

The standards and conventions in most common use and hence those required for a basic understanding of engineering drawing are illustrated and explained in this book.

Language

- 1 It is the media of communication (Fig 1)

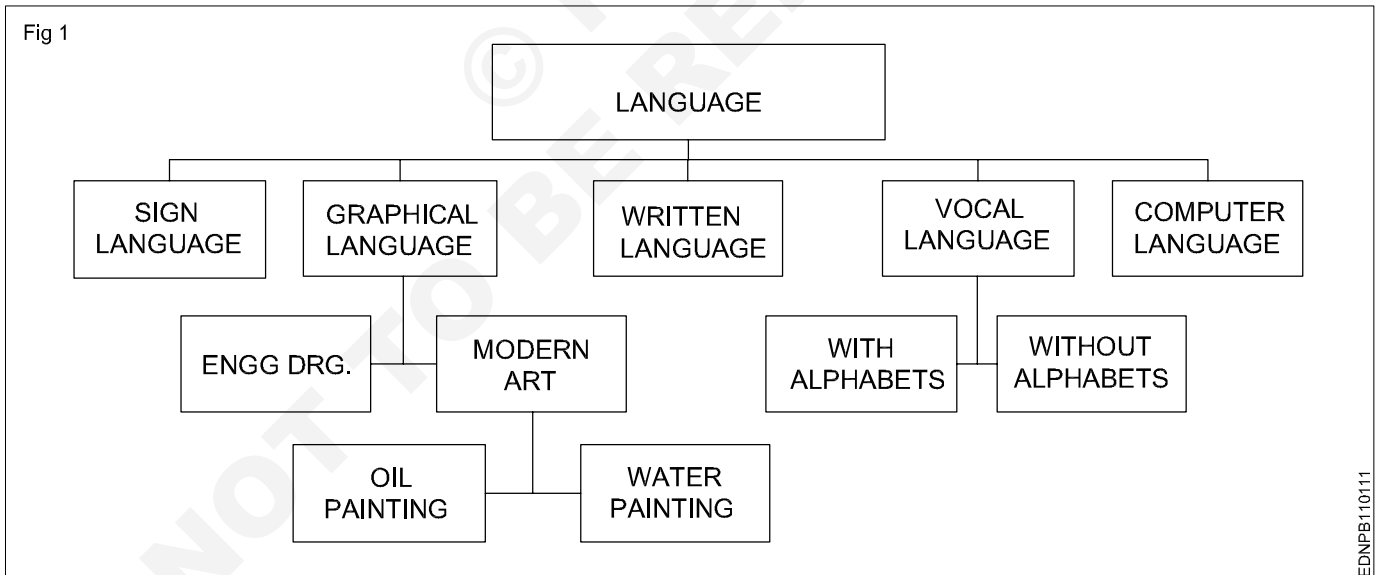

EDNPB110111

Conclusion

Effective communication is possible when graphical language is supported by written language/vocal language and vice versa.

Engineering drawing is a language that uses both graphical language and written language for effective communication.

Engineering drawing is a graphical language that also uses written language for effective communication.

The importance of Engineering Drawing

The economic success of any country is mainly dependent on its industrial development. Due to globalization, any industry in our country is expected to be of a global market standard. For the above-mentioned reasons, our Indian products require very high quality for their size, dimension, fit, tolerance, and finish etc.

To produce the best standard product, all the technical personnel (Engineers to Craftsman) in an industry must have a sound knowledge of engineering drawing because engineering drawing is the language of engineers. Engineering drawing is a universal language. Different types of lines make up their alphabets. Technical personnel in any industry, including craftsman, are expected to communicate anything concerning a part or a component by means of drawings involving lines, symbols, conventions, abbreviations etc.

With our spoken languages, it is impossible to express the details of a job or a product. Engineering drawing knowledge and practise are a must for designing or producing a component or part. Even a small mistake in the drawing may reflect very badly on the product. Therefore, reading and doing engineering drawings are very essential for craftsmen and engineers.

A drawing is a graphical representation of an object, or part of it, and is the result of creative thought by an engineer or technician. When one person sketches a rough map in giving direction to another, this is graphic communication. Graphic communication involves using visual materials to relate ideas. Drawings, photographs, slides, transparencies, and sketches are all forms of graphic communication. Any medium that uses a graphic image to aid in conveying a message, instructions, or an idea is involved in graphic communication.

One of the most widely used forms of graphic communication is the drawing. Technically, it can be defined as **"a graphic representation of an idea, a concept or an entity which actually or potentially exists in life"**

Drawing is one of the oldest forms of communicating, dating back even farther than verbal communication. The drawing itself is a method of communicating necessary information about an abstract, such as an idea or concept or a graphic representation of some real entity, such as a machine part, house or tools. There are two basic types of drawings: Artistic and Technical drawings.

Technical drawings

Technical drawings allows efficient communication among engineers and can be kept as a record of the planning process. Since a picture is worth a thousand words, a technical drawing is a much more effective tool for engineers than a written plan.

The technical drawing, on the other hand is not subtle, or abstract. It does not require an understanding of its creator, only on understanding of technical drawings. A technical drawing is a means of clearly and concisely communicating all of the information necessary to transform an idea or a concept in to reality. Therefore, a technical drawing often contains more than just a graphic representation of its subject. It also contains dimensions, notes and specifications.

Fields of use

Technical drawing is the preferred method of drafting in all engineering fields, including, but not limited to, civil engineering, electrical engineering, mechanical engineering and architecture.

Purpose of studying engineering drawing

- 1 To develop the ability to produce simple engineering drawing and sketches based on current practice
- 2 To develop the skills to read manufacturing and construction drawings used in industry.
- 3 To develop a working knowledge of the layout of plant and equipment.
- 4 To develop skills in abstracting information from calculation sheets and schematic diagrams to produce working drawings for manufacturers, installers and fabricators.

Main types of Engineering drawing

Regardless of branch of engineering the engineering drawing is used. However based on the major engineering branches, engineering drawing can be classified as follows: (Fig 2)

Mechanical engineering drawings

Some examples of mechanical engineering drawings are part and assembly drawings, riveted joints, welded joints, fabrication drawings, pneumatics and hydraulics drawings, pipeline diagrams, keys coupling drawings etc. (Fig 3&4)

Electrical engineering drawing

Wiring diagrams of home and industries, circuit diagrams, electrical installation drawings etc.

Example

The voltage supply to a filament lamp is 10.8V. The voltage should be 12V. (Fig 5)

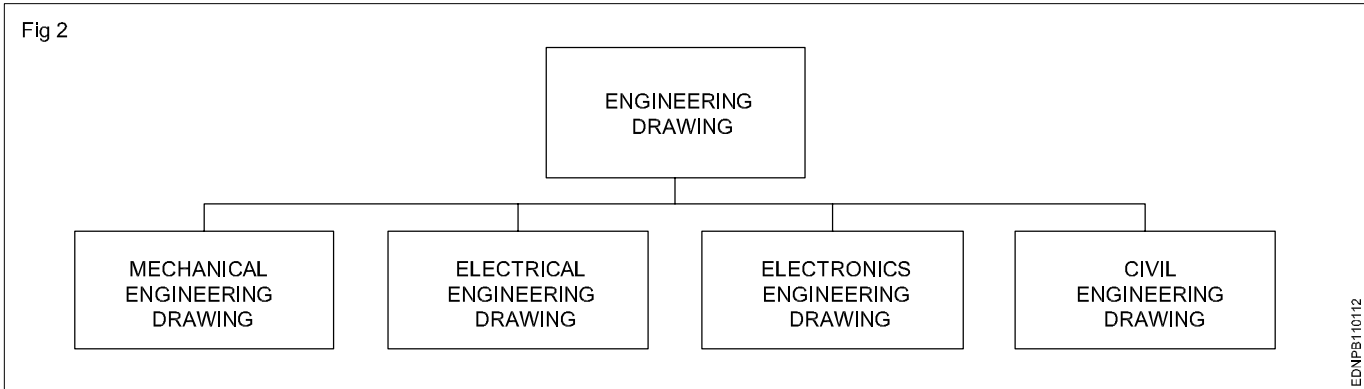

Mechanical Engineering Drawings (Fig 3&4)

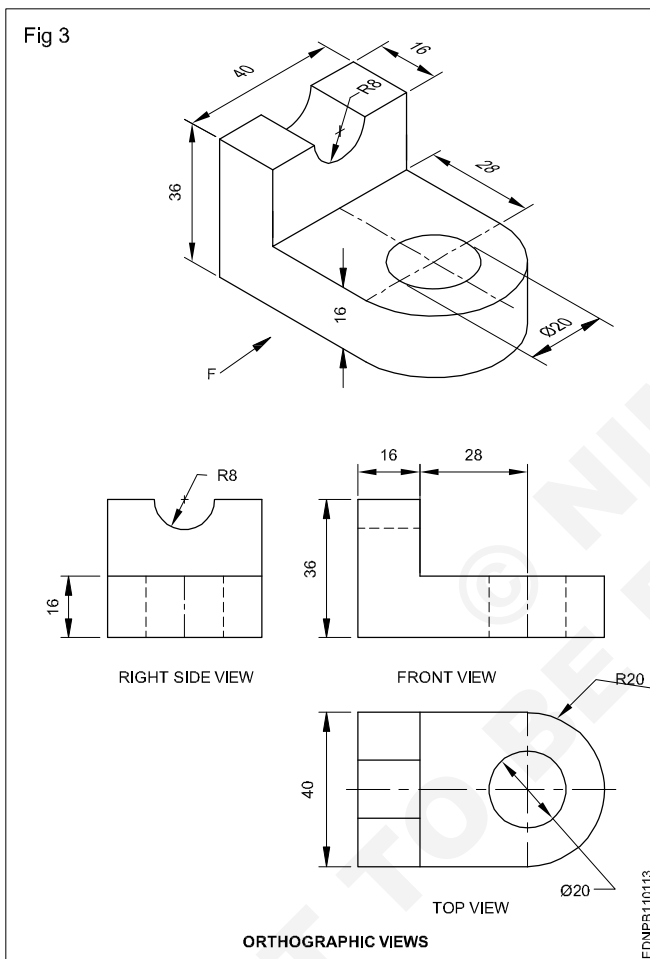

Electrical Engineering Drawing (Fig 5)

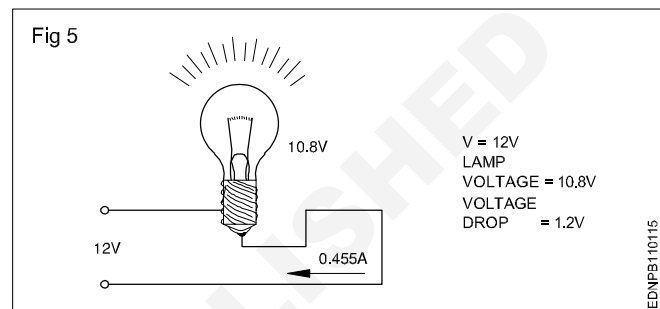

Electronics Engineering Drawing

Audio amplifier (Fig 6)

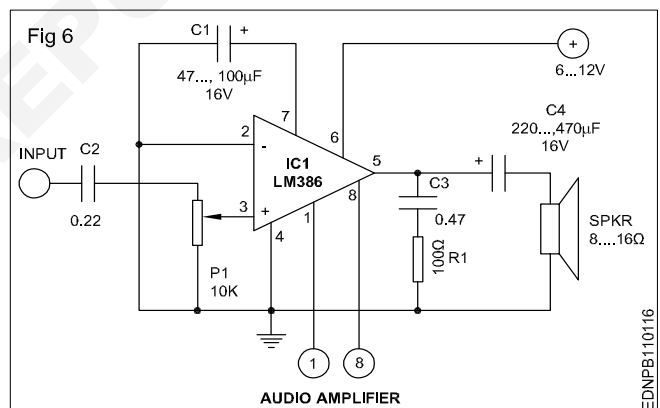

Civil Engineering Drawing (Fig 7)

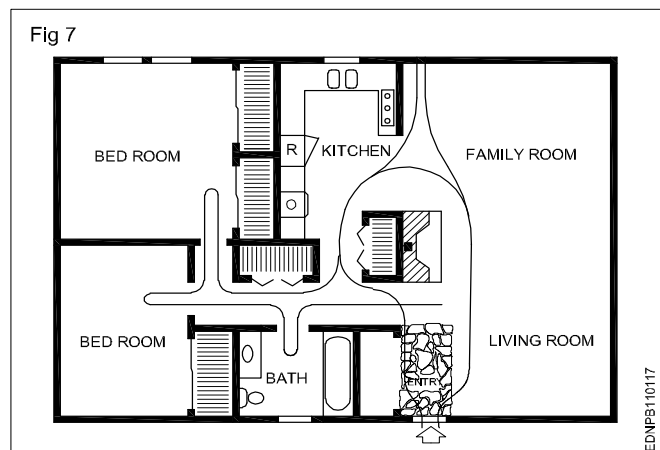

Conventions

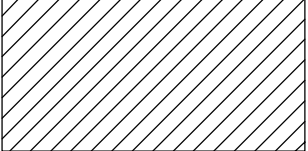
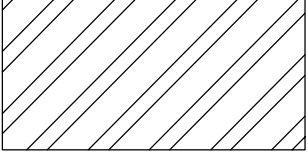
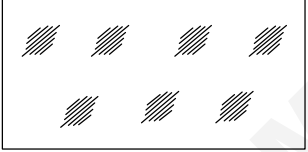
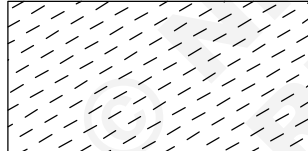
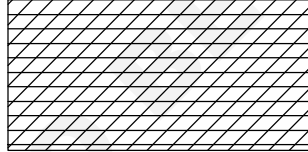
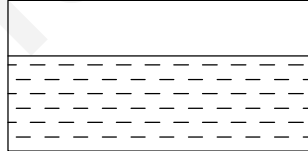
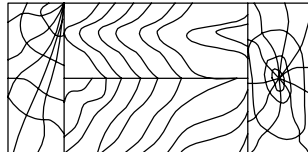
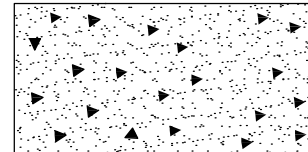
TYPE	CONVENTION	MATERIALS
Metals		Steel, Cast Iron, Copper and its Alloys, Aluminium and its alloy, etc
		Lead, Zinc, Tin, White-metal, etc.
Glass		Glass
Packing and Insulating materials		Porcelain, Stoneware, Marble, Slate etc
		Asbestos, Fibre, Felt, Synthetic resin products, Paper, Cork, Linoleum, Rubber, Leather, Wax, insulating & Filling Materials etc
Liquid		Water, Oil, Petrol, Kerosene etc
Wood		Wood, Plywood etc
Concrete		Concrete

Sizes and layout of drawing sheets

Size of drawing sheets (in mm): While being worked on or handled, the drawing sheets are prone to tear along the edges. So slightly larger(untrimmed) sheets are preferred. They are trimmed afterwards. IS:10811:1983 lays down such as designation of preferred trimmed and untrimmed sizes.

Designation of sheets: The drawing sheets are designated by symbols such as A0, A1, A2, A3, A4 and A5. A0 being the largest and A5 is smallest. Table 1 below gives the length and breadth of the above sizes of sheets. (Trimmed and untrimmed)

The relationship between two sides is same as that between a side of a square and its diagonal.

TABLE 1

Designation	Trimmed size	Untrimmed size
A0	841 x 1189	880 x 1230
A1	594 x 841	625 x 880
A2	420 x 594	450 x 625
A3	297 x 420	330 x 450
A4	210 x 297	240 x 330
A5	148 x 210	165 x 240

Special elongated series increasing its widths, double, treble etc. are denoted as follows A3 x 3, A3 x 4, A4 x 3, A4 x 4, A4 x 5. Please refer Table 2.

TABLE 2

Special elongated series

Designation	Size
A3 x 3	420 x 891
A3 x 4	420 x 1189
A4 x 3	297 x 630
A4 x 4	297 x 841
A4 x 5	297 x 1051

Fig 1 & 2 shows how the sheet sizes are formed by halving/doubling and similarity of format.

White drawing papers that do not turn yellow on exposure to air are used for finished drawings, maps, charts and drawings for photographic reproductions.

For pencil layouts and working drawings, cream-coloured papers are best suited.

Quality drawing paper: The drawing papers should have sufficient teeth or grain to take the pencil lines and withstand repeated erasing.

To get uniform lines, backing paper is to be placed on the drawing board before fixing drawing/tracing paper,. Before starting the drawing, the layout should be drawn. (Ref: IS:10711)

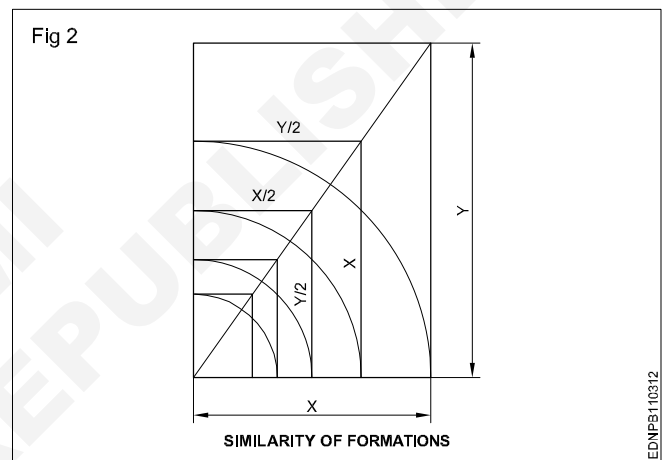
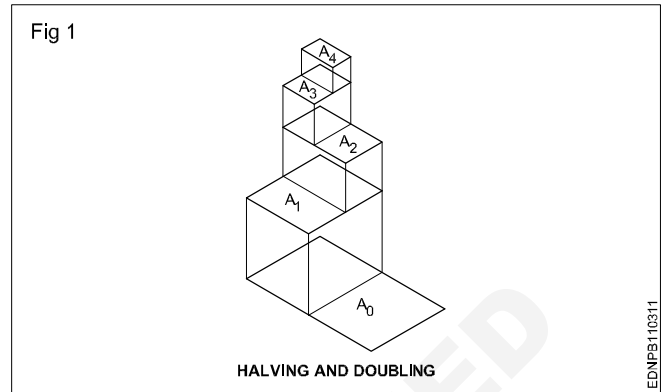

The following is the method of folding printed drawing sheets as recommended by BIS. (Fig 3)

Method of folding of printed drawing sheets as per BIS SP: 46-2003

When drawings sheets are in more numbers, they have to be folded and kept in order to save the trace required for preserving them (Fig 4).

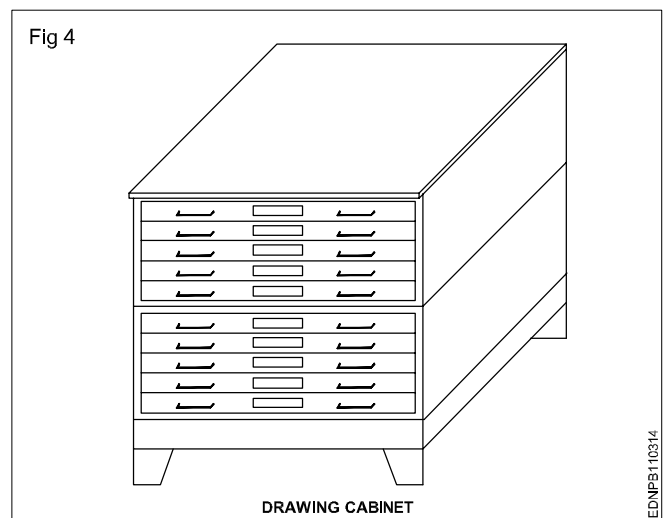

EDNFB110311

EDNFB110312

EDNFB110314

Method of folding printed drawing sheets (Fig 3)

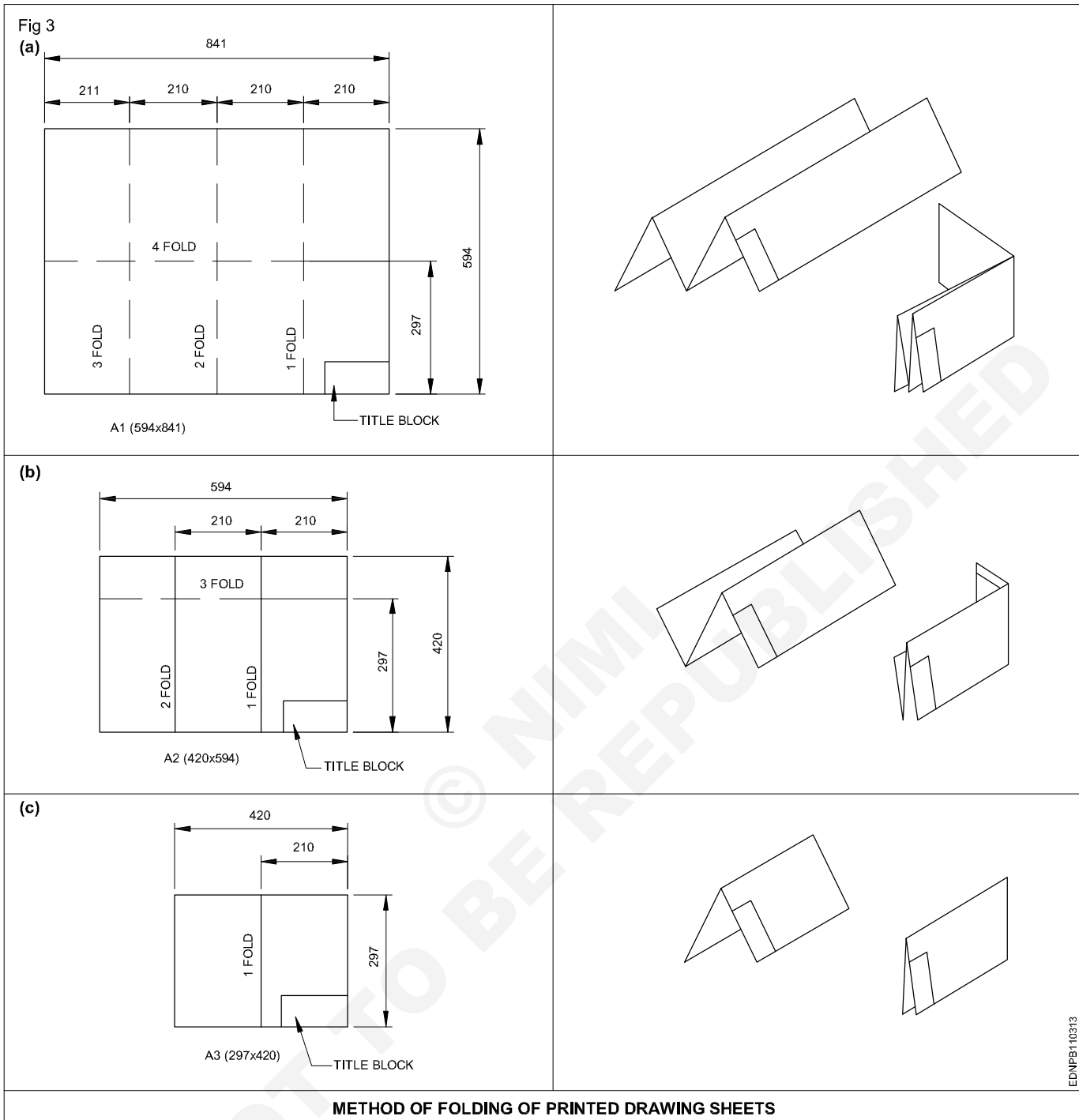

Title block, its position and content

Layout of drawing sheet:

As a standard practice sufficient margins are to be provided on all sides of the drawing sheet. The drawing sheet should have drawing space and title space. A typical layout of a drawing sheet is shown in the (Fig 1 & 2).

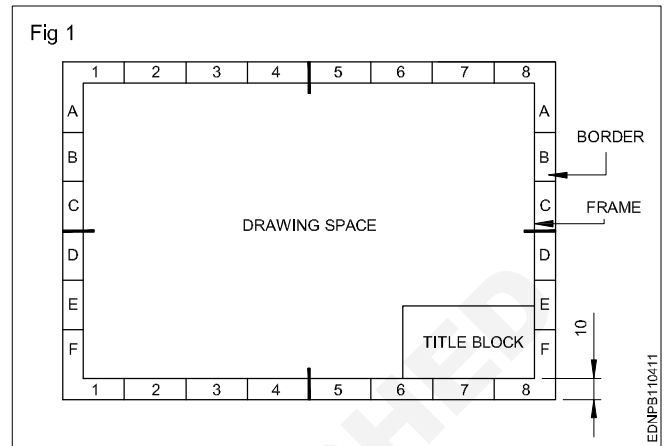

Title Block - 1

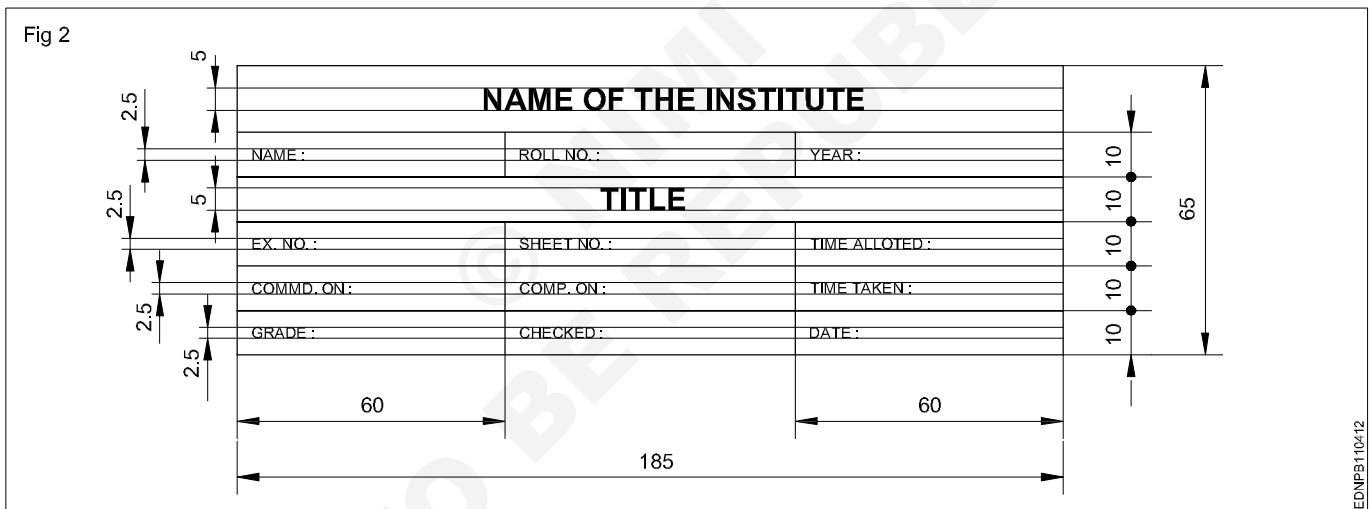

Title Block - 2

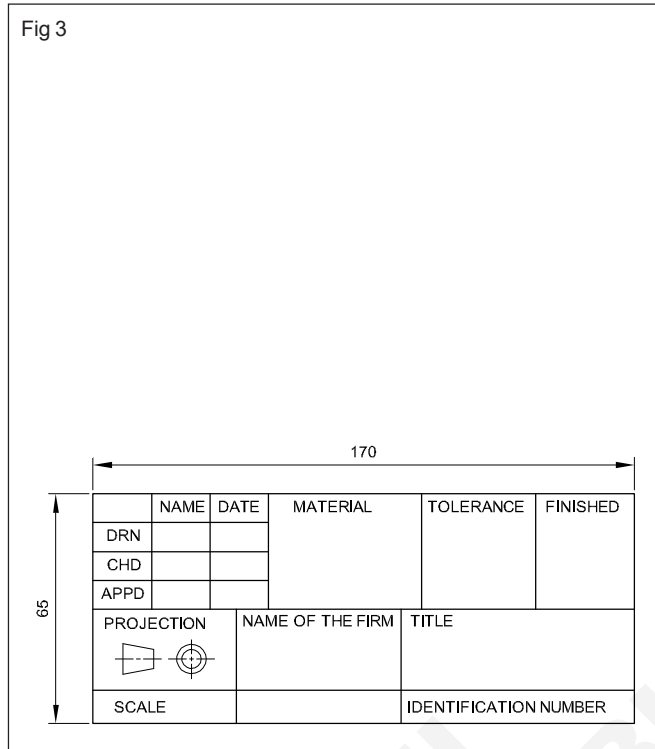

Title Block - 3

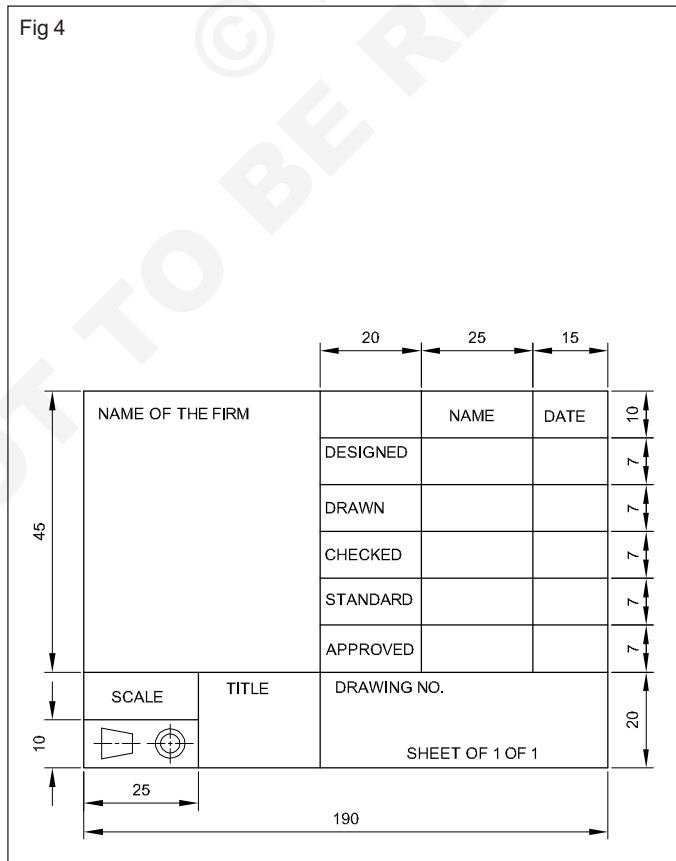

Title Block - Position and content - 1

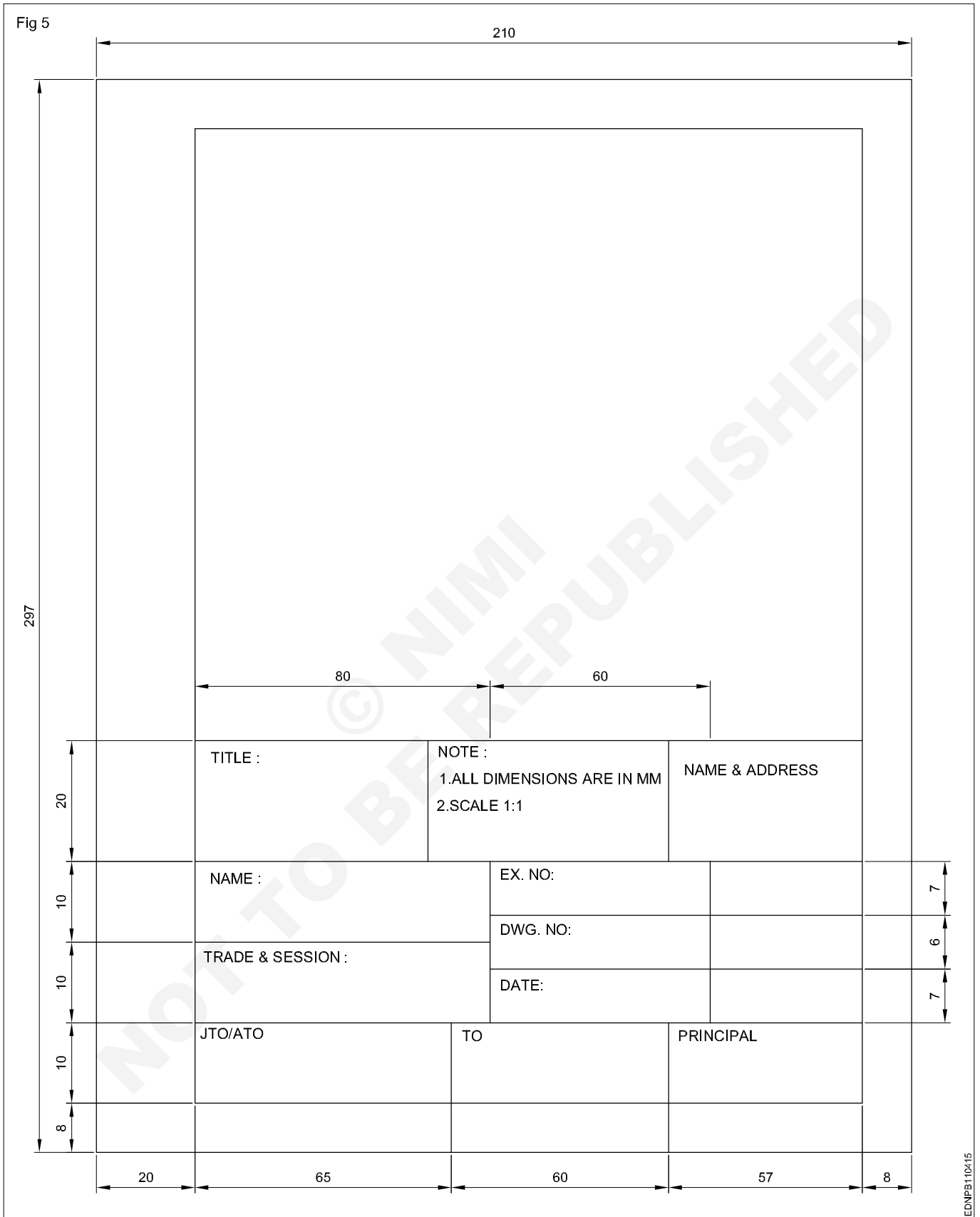

Title Block - Position and content - 2

Fig 6

DO NOT SCALE

REVISION			
SL.N	DESCRIPTION	DATE	APPX
A	M12 WAS $\frac{1}{2}$ WHIT.	14.12.18	A.W.D

4			
3			
2			
1	A7325	VALVE BODY	1
DRG OR PART NO.	DESCRIPTION	QTY.	

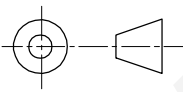
UNLES OTHERWISE STATED ALL DIMENSIONS IN MILLIMETRES. TOLERANCES LINEAR: ANGULAR:		DRN 1:1:78 JKL	(NAME OD THE FIRM)
		CKD 2:1:78 MLN	
		APPD 5:1:78 AWB	(TITLE OF DRW.)
		ISSUED 4:2:78 PFP	
	MATERIAL : CAST STEEL		
DRAFTING STANDARD AS 1100	FINISH AS MACHINED		
		SIZE A3	DRG NO A24641
		SCALE 1:2	SHEET 1 OF 1

EDNPPB110416

Item Reference on Drawing Sheet

05	TIGHTENING PIN	01	MILD STEEL	
04	WORK PIECE	01	ANY MATL.	
03	SCREW ROD	01	STD.	
02	"U" CLAMP	01	CAST IRON	
01	"V" BLOCK	01	CAST IRON	
PART NO	DESCRIPTION OF ITEM	QTY/ASSY	MATERIAL	REMARKS
BILL OF MATERIALS				

The drawing sheet on which the drawings to be prepared should be prepared first by following the procedure given below:

- 1 Take A4/A3 drawing sheet.
- 2 Mark the borders and draw the title block as mentioned.
- 3 Follow the same procedure for A3 drawing sheet where the title block is to be drawn right side bottom corner and the border dimensions remain same.
- 4 Title block to be drawn whenever the title of the drawing changes. Eg. for the geometrical construction chapter the title block may be drawn in the first sheet only where as on the remaining sheets borders to be drawn before they are used for preparing drawings.

Drawing instruments

The following are the commonly used equipment in a drawing office.

Drawing board (Fig 1): Drawing board is one of the main item of equipment for Draughtsman. It is used for supporting the drawing paper/tracing paper for making drawings. It is made of well-seasoned wood strips of about 25 mm thick or masonite, free from knots and warping. It should be softer enough to allow insertion and removal of drawing pins. Two battens are fastened to the board by screws, in slotted joints. They prevent warping and at the same time permit expansion and contraction of the strips due to the change of moisture in the atmosphere.

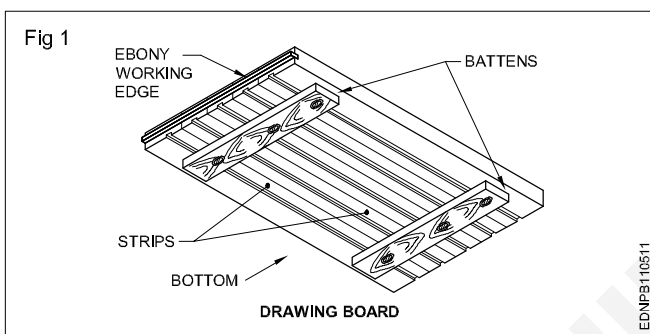

One of the shorter edges of the drawing board is provided with an "ebony edge" (hardwood) fitted perfectly straight.

Standard drawing boards are designated as follows as per IS:1444-1989.

Sl. No.	Designation	Size (mm)
1	D0	1500 x 1000 x 25
2	D1	1000 x 700 x 25
3	D2	700 x 500 x 15
4	D3	500 x 350 x 15

The working edge (ebony) must be straight.

Now-a-days drawing boards are available with laminated surfaces. The flatness can be checked by placing a straight edge on its surface. If no light passes between them, the surface is perfectly flat.

'T' Square: It is of 'T' shape, made of well-seasoned wood. It has two parts., head/stock and blade. One of the edges of the blade is the working edge. The blade is screwed to this head such that the working edge is at a right angle to the head. (Fig 2a)

The standard 'T' square is designated as follows with dimensions shown in mm; as per IS:1360-1989.

Sl. No.	Designation	Blade length
1	T0	1500
2	T1	1000
3	T2	700
4	T3	500

The 'T' square is used with its head against the ebony edge of the drawing board to draw horizontal lines, and parallel lines and to guide/hold the set squares, stencils etc.

Fig 2b shows how the 'T' square is used.

'T' square should never be used as a hammer or as a guide for trimming papers.

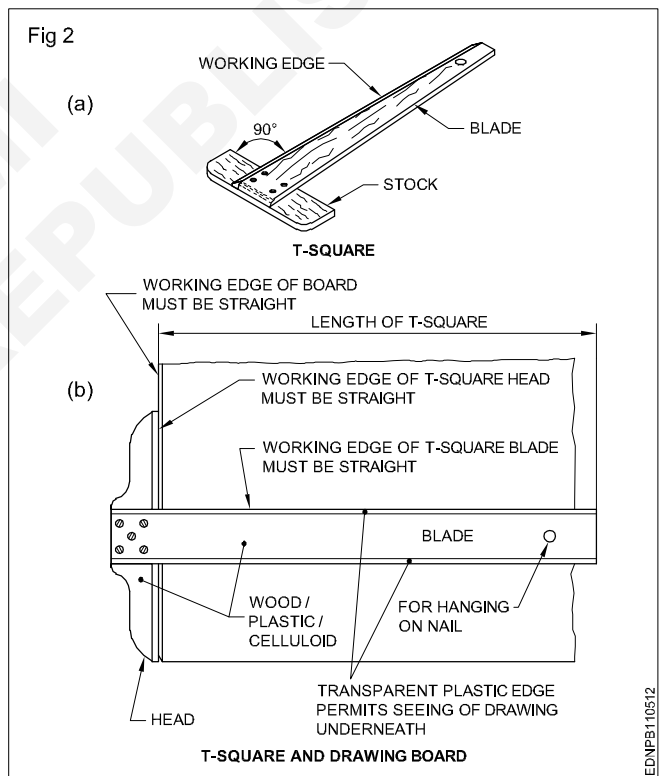

Drafting in the machine (Fig 3): It serves the functions of a Tee square, set square, protractor and scale. They come in different sizes and have a pattern called the 'Pantograph' type. It is fitted on the top left side, edge of the drafting board, mounted on an adjustable frame or table. It requires a large area of working place. The angle of the drafting board can be adjusted by the pedal operating system. There are two counterweights to balance the angular position of the board and the drafting head. It is more suitable for the production drawing office.

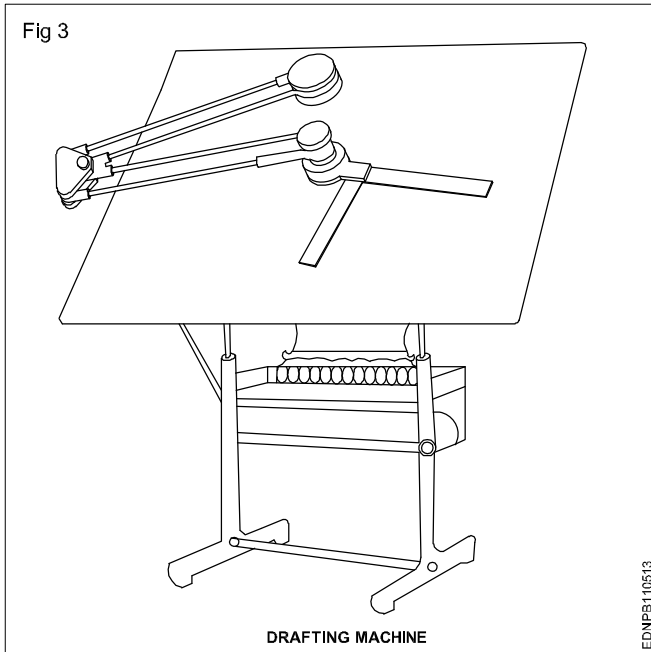

On the other end, a protractor head H with swivelling and locking arrangement is fitted with two scales at right angles.

The protractor head has a spring-loaded clutch relieving handle, which rotates and locks at 15° intervals automatically. For setting any angle other than multiples of 15°, the clutch spring is released and by rotating the centre knob, the zero line is set to the required angle and the friction clutch knob is tightened. It is capable of rotating 180°, thereby any angle can be set.

The scales are bevelled on both sides, graduates to 1:1 & 1:2. They can be reversed with the help of dovetail slide fitting.

There is a fine adjusting mechanism on the drafting head to set the scale parallel to the edge of the board. The scales also can be adjusted if there is an error in measuring 90° between them.

The mini drafter is an important device used for making drawing quickly & accurately. This instrument has the combination of T-square, set square, protractor and scales, it helps to draw the drawings at a faster rate. (Fig 4,5 & 6)

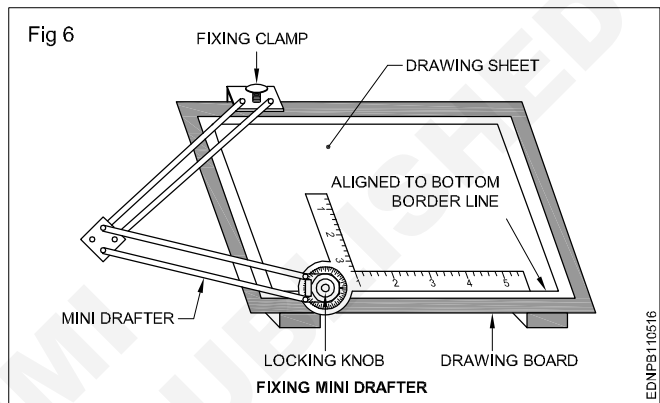
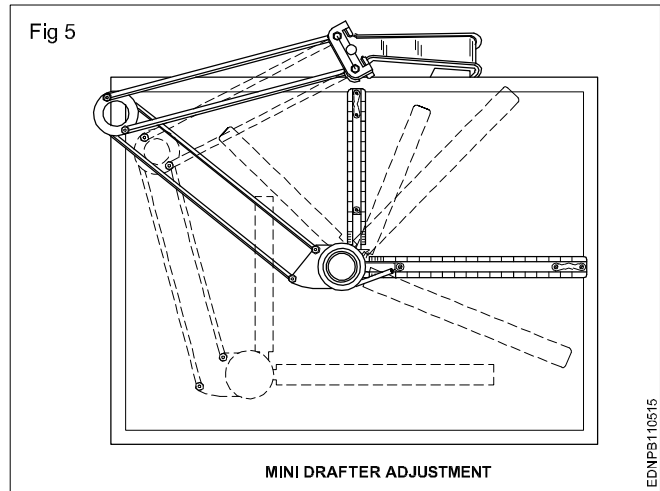
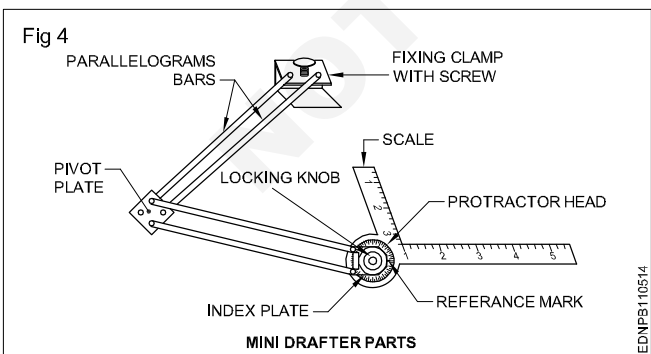

Erasing shield: When, on a drawing, if a part of a line or some lines among many other lines needs to be erased or modified, in a normal way erasing will damage the other nearby lines. In such a situation an erasing shield is effectively useful. It is a thin metallic sheet having small openings of different sizes and shapes. A suitable opening is aligned to the line to be erased and the line is removed by the eraser. (Fig 7)

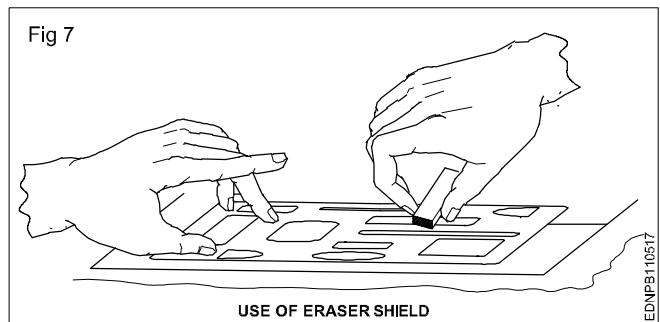

Set square (IS:1361-1988): Transparent celluloid /Plastic set squares are preferred and are commonly used rather than ebonite ones. They are two in number, each having one corner with 90°. The set square with 60° & 30° of 250 mm long and 45° of 200mm long is convenient for use. (Fig 8)

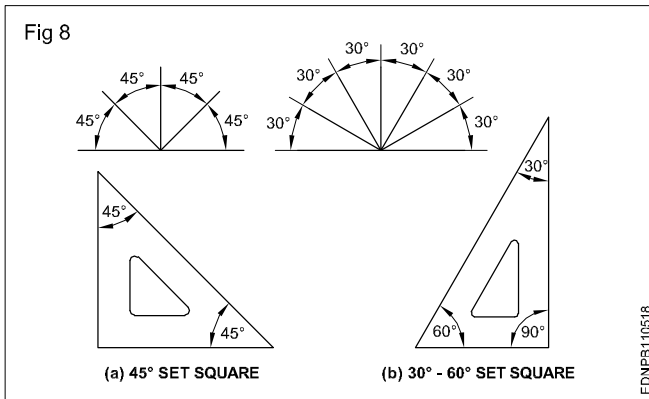

Scales: Scales are used to transfer and or measure the dimensions. They are made of wood, steel, ivory, celluloid or plastic, stainless steel scales are more durable. different types of scales used are shown in Fig 9. They are either flat, bevel-edged or triangular cross-sections. Scales of 15cm long, 2cm wide or 30cm long 3.5cm wide are in general use.

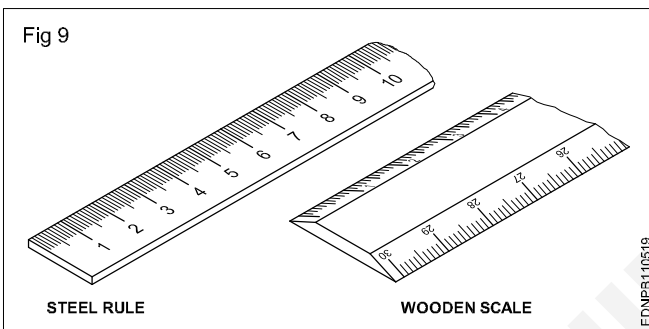

Protractor: A protractor is an instrument for measuring angles. It is semi-circular or circular and is made of a flat celluloid sheet.

The angles can be set or measured from both sides, aligning the reference line and point '0' with the corner point of the angle.

Figure 10 shows how to read or set the angle. A protractor can also be used to divide a circle or draw sectors.

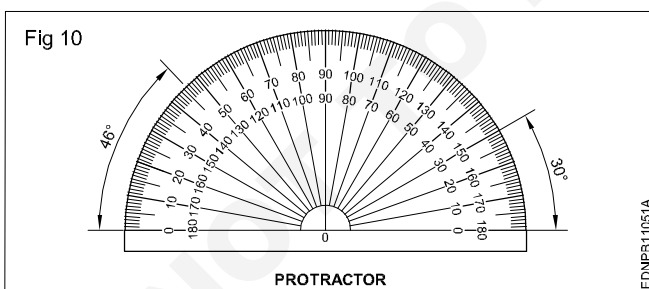

French curves (Fig 11)

These are made in many different shapes, normally come in sets of 6, 12, 16 etc. French curves are best suited to draw smooth curves/arcs (which cannot be drawn by a compass) with ease. To draw a smooth curve using a french curve first set it by trial against a part of the line to be drawn, then shift it to the next portions.

Fig 12 shows how to use the french curve and draw smooth curves. They are made of transparent celluloid (no bevel edge).

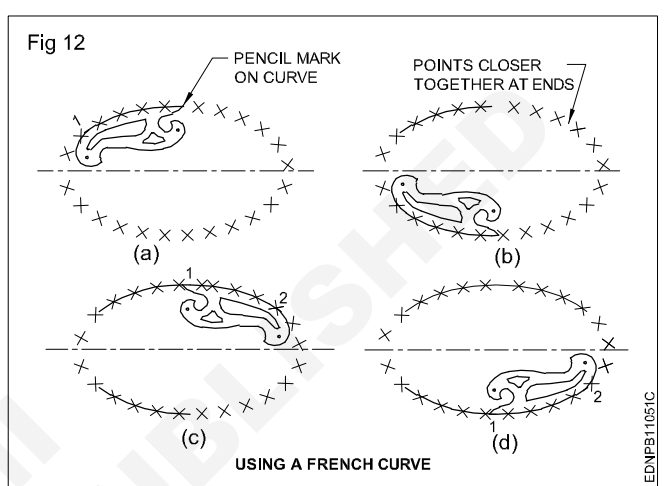
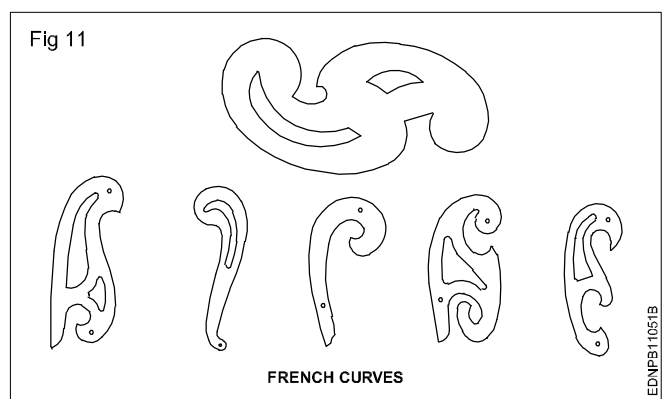

An instrument box contains the following: (Fig 13a to h)

- Large compass (with attachment facility) (a)
- Large divider (b)
- Bow compasses(pencil/ink), bow divider (c)
- Lengthening bar (d)
- Pen point for attachment (e)
- Screwdriver (f)
- Lead case (g)
- Liner (h)

Large compass (Fig 14): It has a knee joint in one leg that permits the insertion of a pen or pencil point or attaching a lengthening bar with a pen or pencil point attached to it. It is used for drawing large circles/arcs and also for taking large measurements.

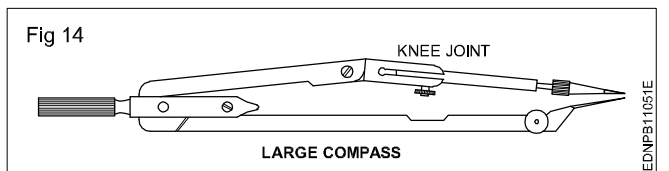

As a rule, while drawing concentric circles, small circles should be drawn first before the centre hole gets worn.

Large divider: It is used to transfer dimensions and divide lines into several equal parts. Divider with adjustable joints is preferable rather than plain legs. (Fig 15)

Fig 13

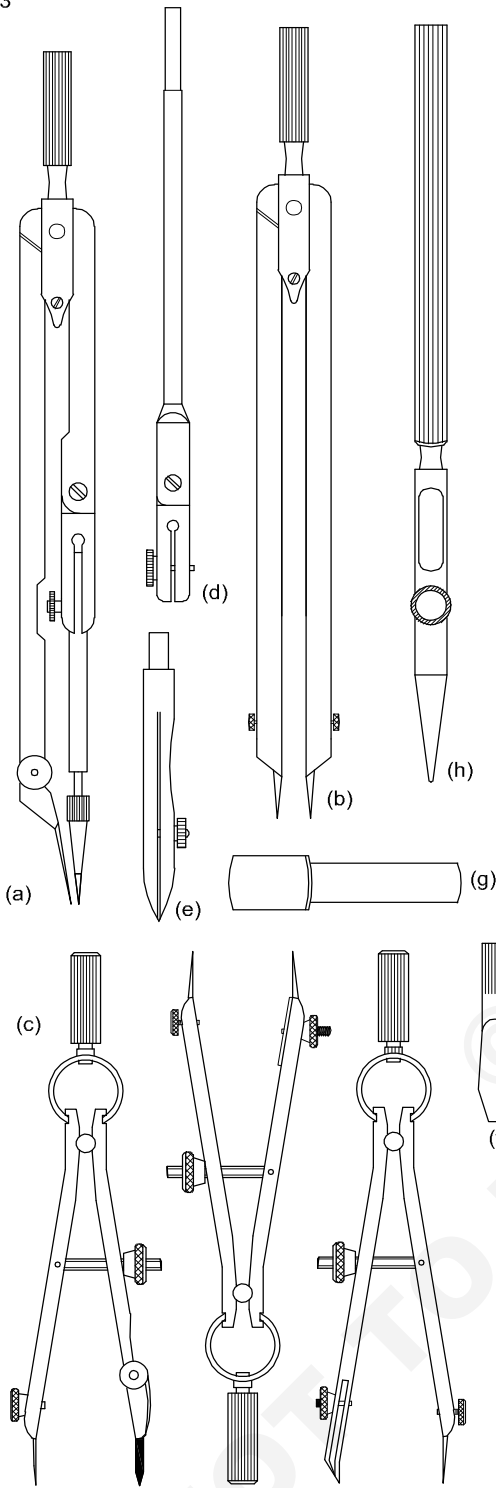

DRAWING INSTRUMENTS

EDNPB11051D

Fig 15

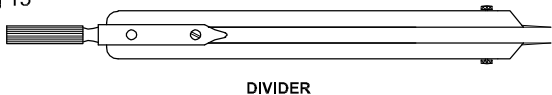

DIVIDER

EDNPB11051F

Bow instruments: Bow pencil and bow pen compass are used for drawing circles of approximately 25 mm radius. A bow divider is used for marking or dividing smaller spaces. There are two types (i) Integral legs with spring action (ii) two legs are held with a curved spring on top with a handle on it.

Fig 16 shows different types of bow instruments. Adjustments should be made with the thumb and middle finger.

Fig 16

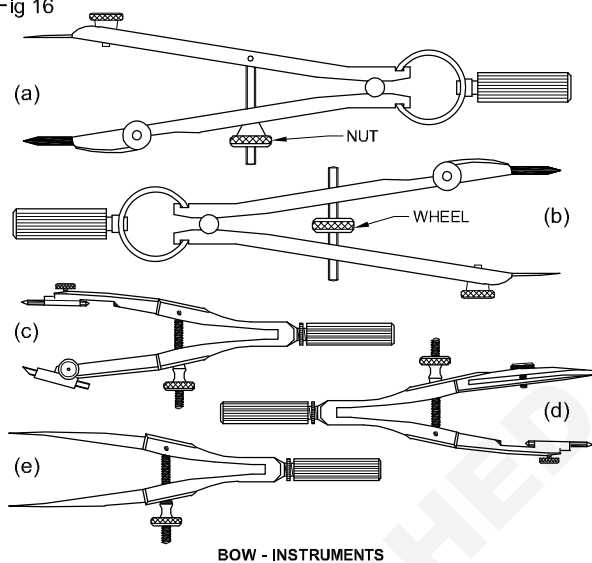

BOW - INSTRUMENTS

EDNPB11051G

Drop spring bow pencil and pen (Fig 17): Drop spring bow pencil and pen are designed for drawing multiple identical small circles. Example: rivet holes, drilled/reamed holes. The central pin is made to move freely up and down through the tube attached to the pen or pencil unit.

Fig 17

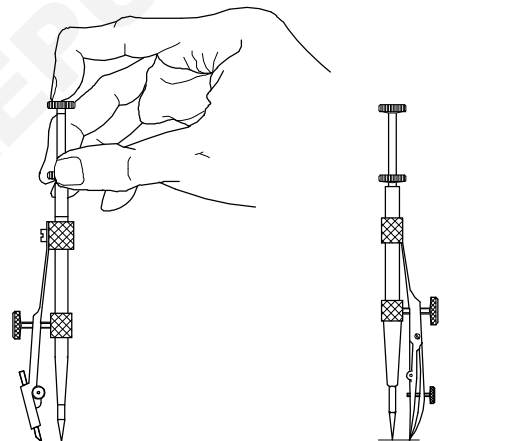

DROP SPRING BOW PENCIL

DROP SPRING BOW PEN

DROP SPRING BOW INSTRUMENT

EDNPB11051H

Inking pen or liner or ruling pen (Fig 18): It is used to ink the straight lines drawn with the instruments but never for freehand lines or lettering.

Fig 18

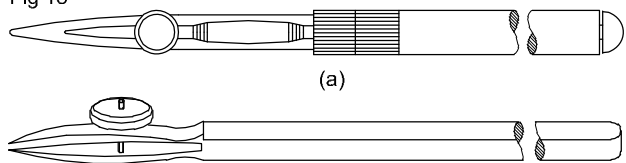

(a)

(b)

RULING PENS

EDNPB11051I

Lengthening bar (Fig 19): To draw larger circles, it is fitted to the compass. The pencil point or pen point is inserted into its end.

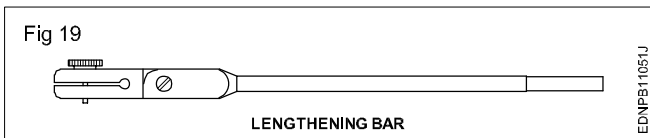

Replaceable spare pencils, pens and needle points for the compass are available in the instrument box.

Screwdriver (Fig 20): Used for adjusting the screws of the instruments.

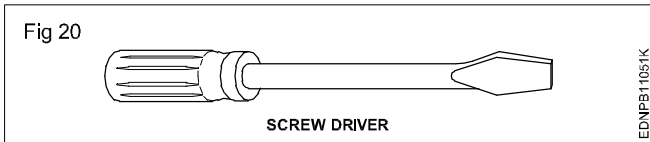

Lead case (Fig 21): Lead case is the box for holding the pencil leads.

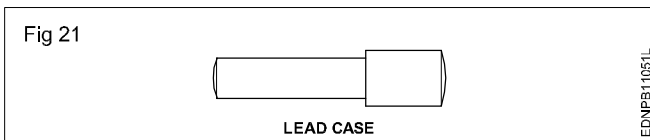

Pin, Clip, Cello tape: Drawing sheet should be fastened onto the drawing board firmly temporarily so that it does not shake during preparing the drawing. For this purpose, the pins, clips and cello tapes are used (Fig 22)

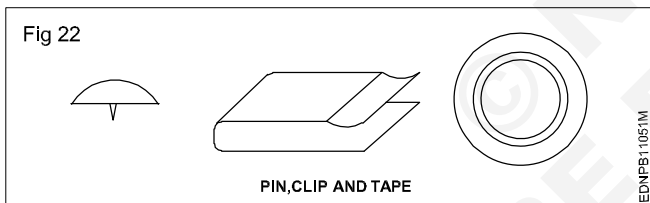

Pencils, Grade and Selection (Fig 23)

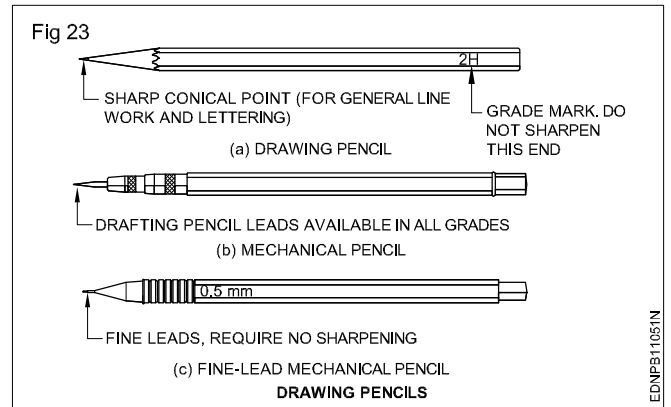

Grades of pencils: Pencils are graded according to the hardness or softness of the lead.

The hardest pencil is 9H grade and the softest pencil is 7B grade. The selection of the grade of pencils depends on the type of line work required and the paper on which it is used.

Softer lead pencils are used to produce thicker and darker line work, but they wear out quickly. Medium grades of H and 2H are used for general line work as well as for lettering.

Selection of pencils: Pencil grades vary from one brand to another brand. Select the grades of the pencil depending upon the type of line work. For construction lines, you can choose 2H or 3H, for lettering and object lines grade H pencils. In general H, HB and 2H are used.

H - medium-hard

HB - medium-soft

2H - hard

Now-a-days automatic (Mechanical) pencils or clutch pencils are available in different sizes (lead dia. 0.3, 0.5, 0.7 or 0.9). Leads can be replaced as per the required grade of hardness. They produce lines of uniform width without sharpening.

Free hand drawing of - Geometrical figures and blocks with dimension









Lines - Types and applications in drawing

Drawings are made up of different types of lines. Just a language with alphabet and grammar.

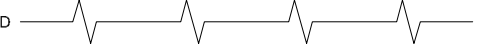
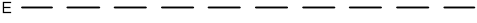
Lines of different thicknesses and features are used for specific use.

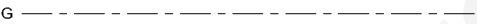
Technical drawings are drawn with different types of lines. By proper choice and application of lines, product features can be correctly defined in a drawing. Different types of lines recommended for specific applications are given in Table 1.

Table 1
Types of lines and their application

Lines	Description	General applications See figure and other relevant figure
A  0.5	Continuous thick	A1 Visible outlines A2 Visible edges
B  0.2	Continuous thin (straight)	B1 Imaginary lines of intersection B2 Dimension lines B3 projection lines or extension line B4 Leader lines B5 Hatching B6 Outlines of revolved sections in place B7 Short centre lines B8 Thread line B9 Diagonal line
C  0.2	Continuous thin free hand	C1 Limits of partial or interrupted views & sections, if the limit is not a chain thin
D  0.2	Continuous thin (Straight) with zig-zags	D1 Line (See figures)
E  0.3	Dashed thick	E1 Hidden outlines E2 Hidden edges
F  0.2	Dashed thin	F1 Hidden outlines F2 Hidden edges
G  0.2	Chain thin	G1 Centre lines G2 Lines of symmetry G3 Trajectories
H  0.3	Chain thin, thick at ends & changes of direction	H1 Cutting planes
J  0.5	Chain thick	J1 Indication of lines or surfaces to which a special requirement applies
K  0.2	Chain thin double-dashed	K1 Outlines of adjacent parts K2 Alternative and extreme positions of movable parts K3 Centroidal lines K4 Initial outlines prior to forming K5 Parts situated in front of the cutting plane
<p>1 This type of line is suited for production of drawings by machines. 2 Although two alternatives are available, it is recommended that on any one drawing, only one type of line be used.</p>		

In the above range, for craftsmen, 0.5 is preferred. This Table shows the 0.5 line range and other lines under this range.

The numbers on the right side of the lines refer to the line thickness in mm.

Geometrical figures and blocks with dimension

Freehand sketching: Apart from making drawing using instruments, often craftsmen will be required to make drawings with their free hand.

Freehand sketching is the easiest method to express the shape of a piece part or a component by an engineer or craftsman.

Freehand sketches are not usually made to scale. However, they should be as nearly to the proportions as possible.

Cube (Fig 1)

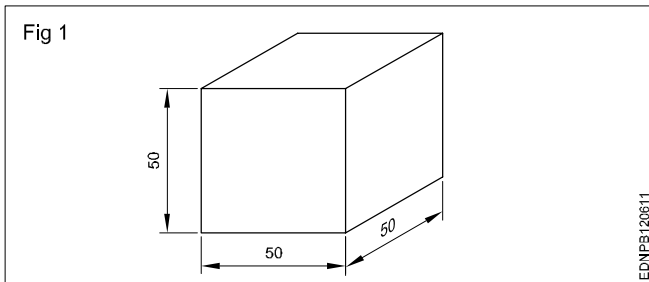

Square block (Fig 2)

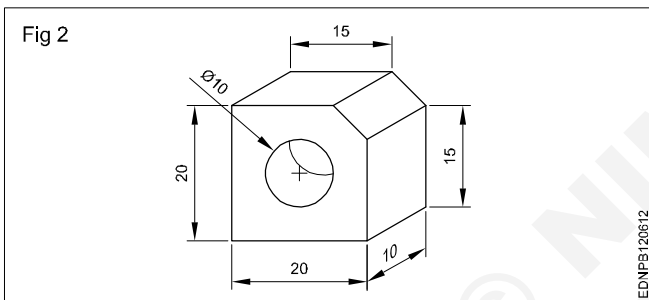

Rectangular block (Fig 3)

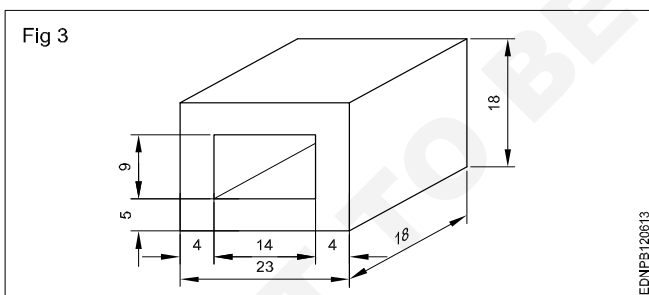

Cube block (Fig 4)

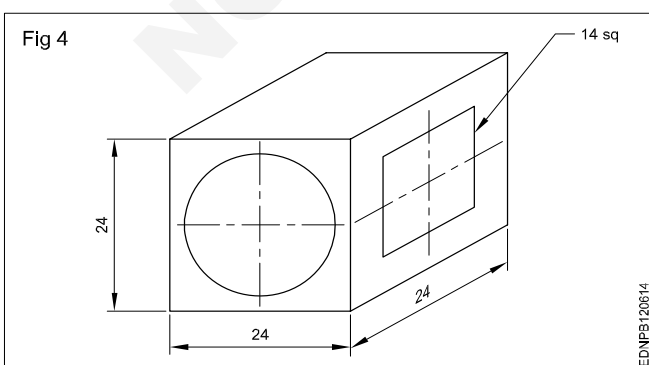

Cylinder (Fig 5)

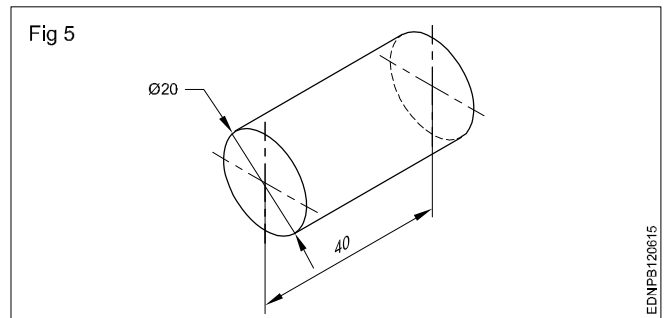

Materials for free hand sketching: A4 size sheet (preferably a pad instead of loose papers) pencils of soft grade. Example H, HB, and a good quality eraser are the only materials required. For drawing different darkness, the pencil points should be sharpened to a conical shape. Fig 6 shows some free hand sketches of different types of views.

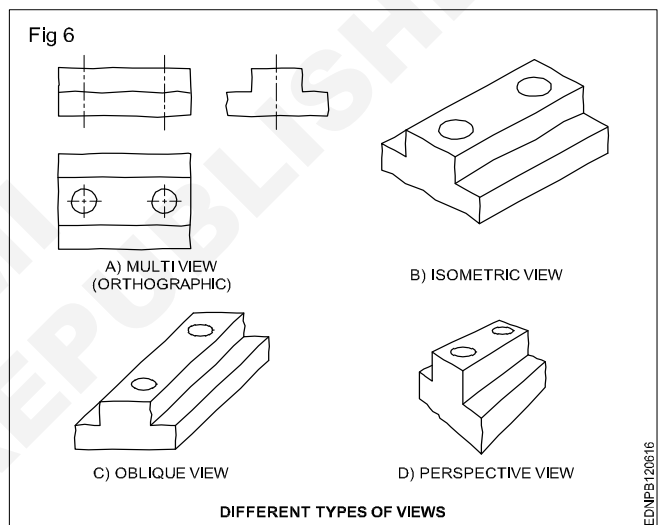

Procedure

Freehand drawing of solid figures, cubes, cuboids, cone, prism, pyramid, frustum of a cone with dimensions

Cube (Fig 1)

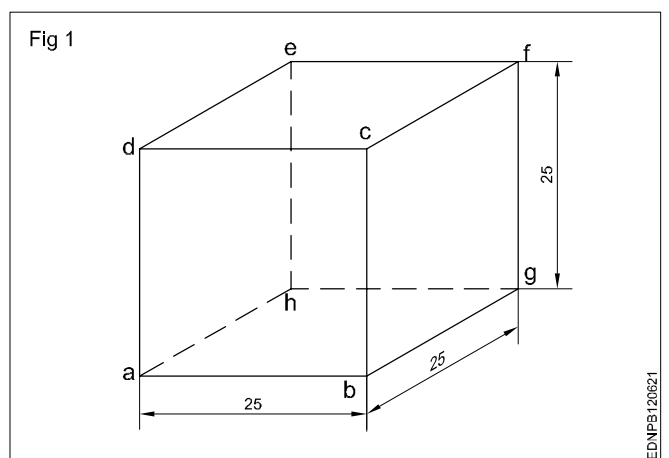

- Draw squares of a, b, c and d.
- Draw 30° from points b, c and d for the length of 25mm.
- Mark point g from b, f from c and e from d as shown in the figure.
- Joint all points.

Cuboid (Fig 2)

Draw the isometric drawing of a cuboid of base 60 mm x 40 mm and the height of 20 mm. (Fig 2)

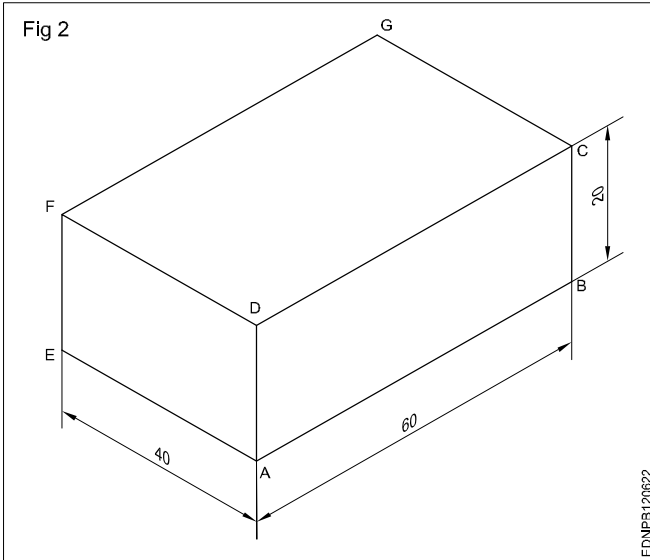

Draw the three isometric axes through the point 'A'.

- Mark AB = 60mm, AE = 40mm and AD = 20mm representing the three sides of cuboid.
- Draw two vertical lines EF and BC parallel to AD from points E and B respectively.
- Similarly, draw two more lines parallel to AB and AE to mark G's interesting point from F and C.
- Draw lines parallel to DC and FG. Draw lines parallel to DF and GC.
- Join all the points.

Cylinder (Fig 3)

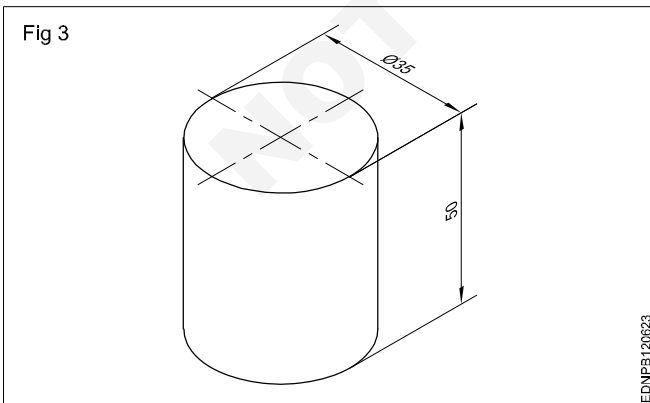

Rectangular prism (Fig 4)

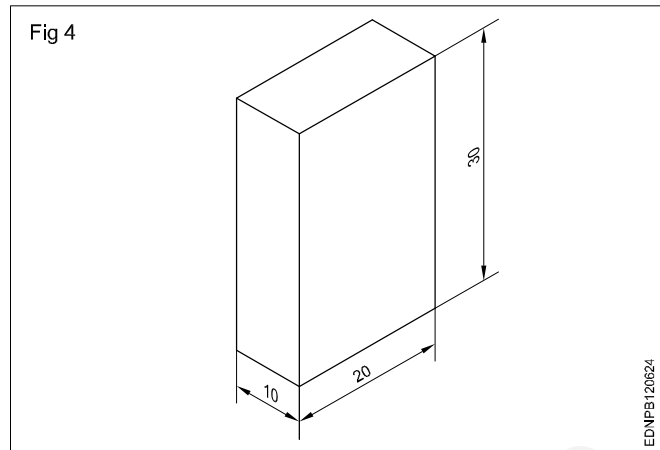

Square Prism (Fig 5)

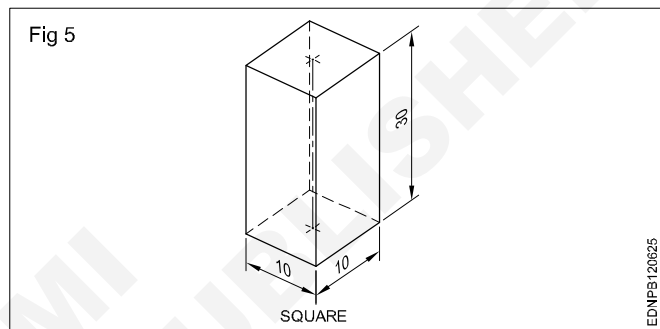

Triangular Prism (Fig 6)

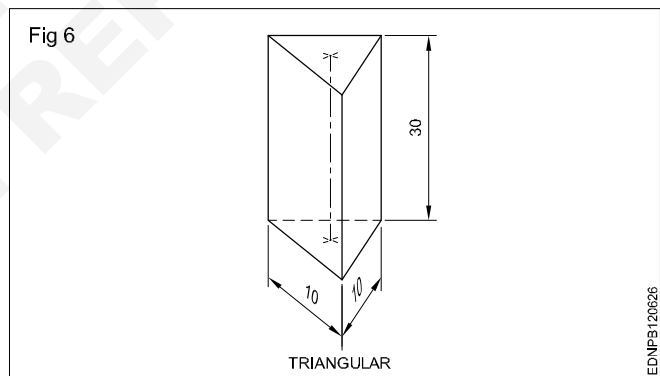

Pentagonal prism (Fig 7)

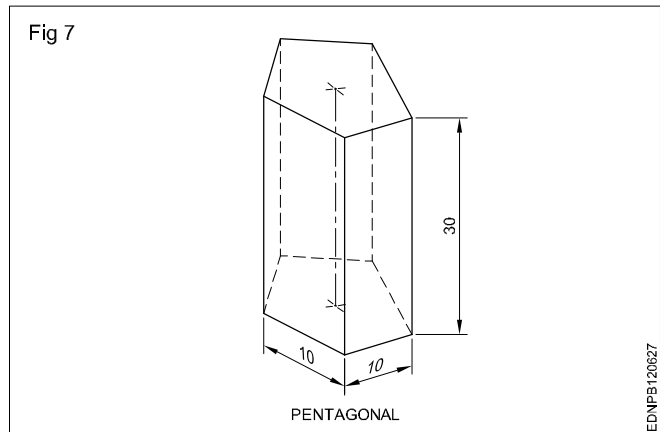

Hexagonal prism (Fig 8)

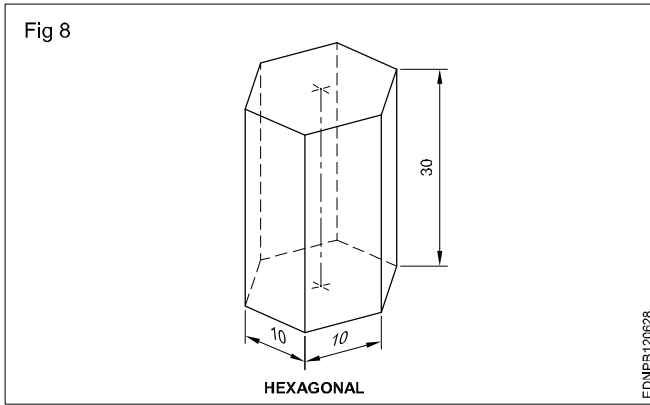

Cone: When a right-angled triangle revolves about one of its sides forming the right angle, a cone is generated. Cone forming has a circular face and a slant curved surface. (Fig 9)

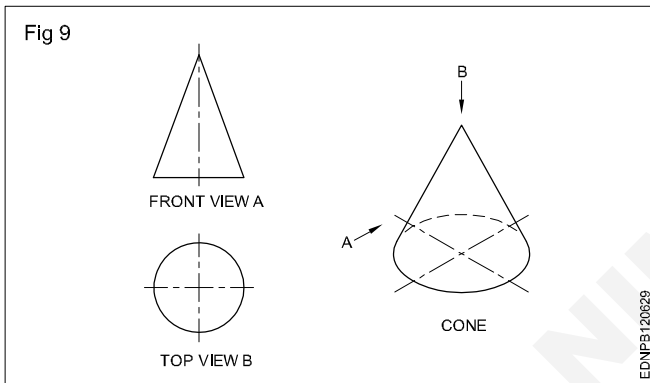

Pyramids: Pyramids are polyhedron solids having a base surface whose shape may be triangular, square or polygon and as many slant triangular faces as there are sides in the base. All the slant triangular faces join at a common point called APEX.

Similar to prisms, pyramids also are known by the shape of their base viz triangular, square, rectangular, pentagonal, hexagonal etc. The imaginary line joining the centre of the base to the apex is called the AXIS.

Fig 10 shows some pyramids and their views.

When a semi-circle revolves about its diameter a sphere is generated. A sphere has no flat surface. (Fig 11D)

Frustums: Pyramid/cone is cut parallel to the base and the top portion is removed. The remaining bottom portion is called the frustum of a pyramid/cone.

If the cutting plane is at an angle to the axis/base, the pyramids or cones are called "Truncated pyramids or cones".

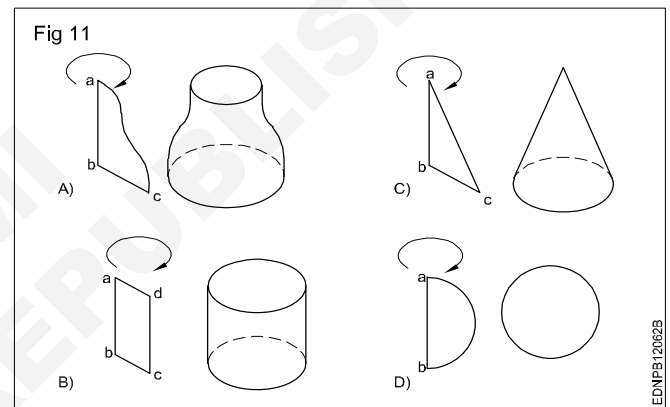
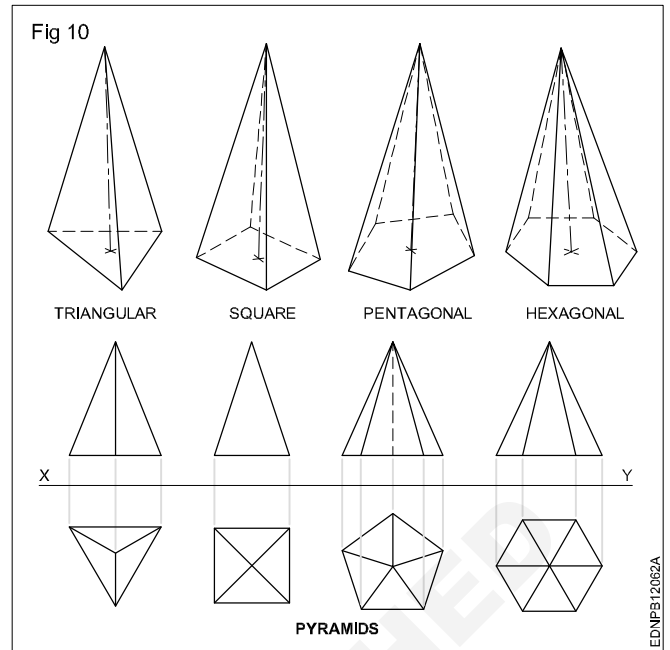
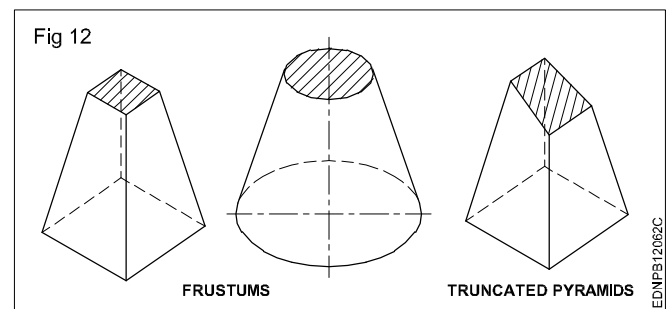
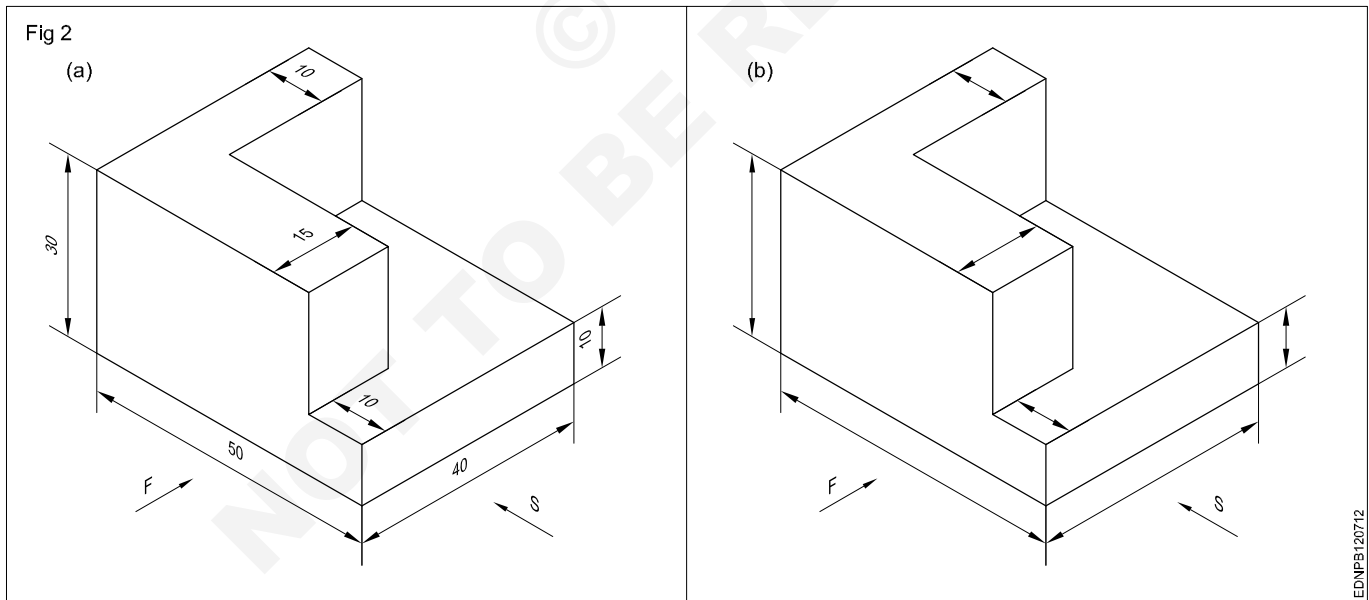
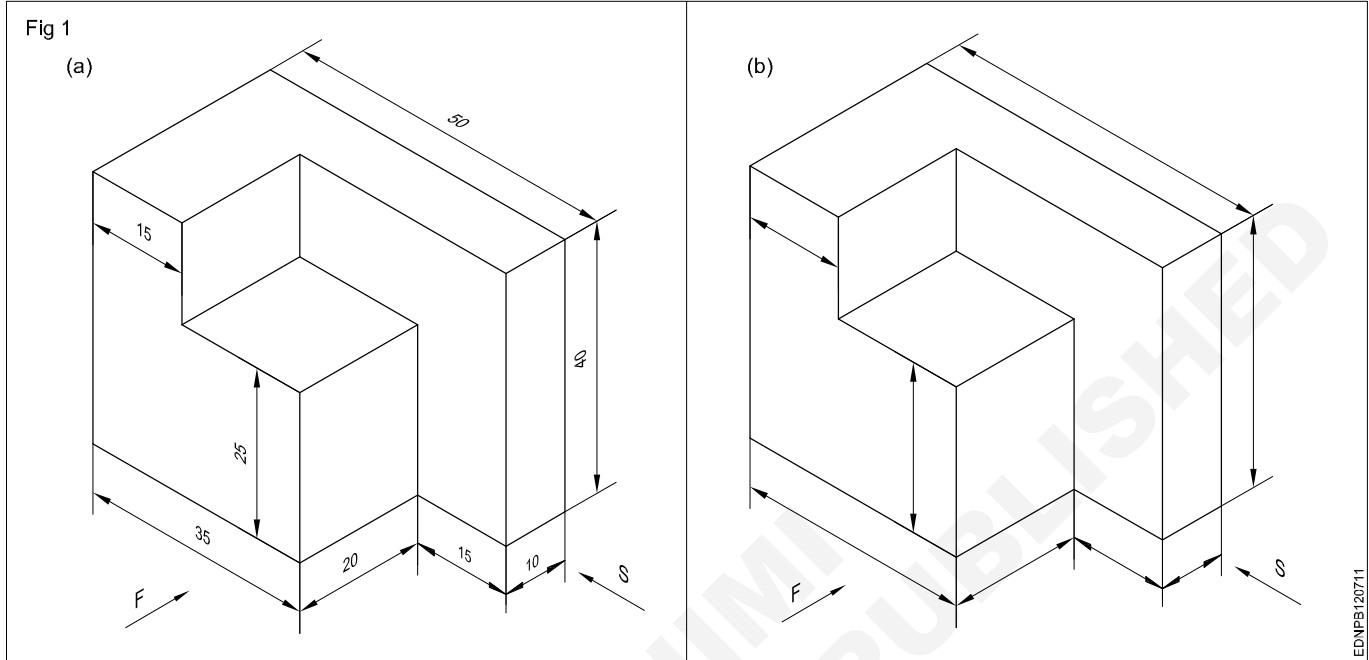
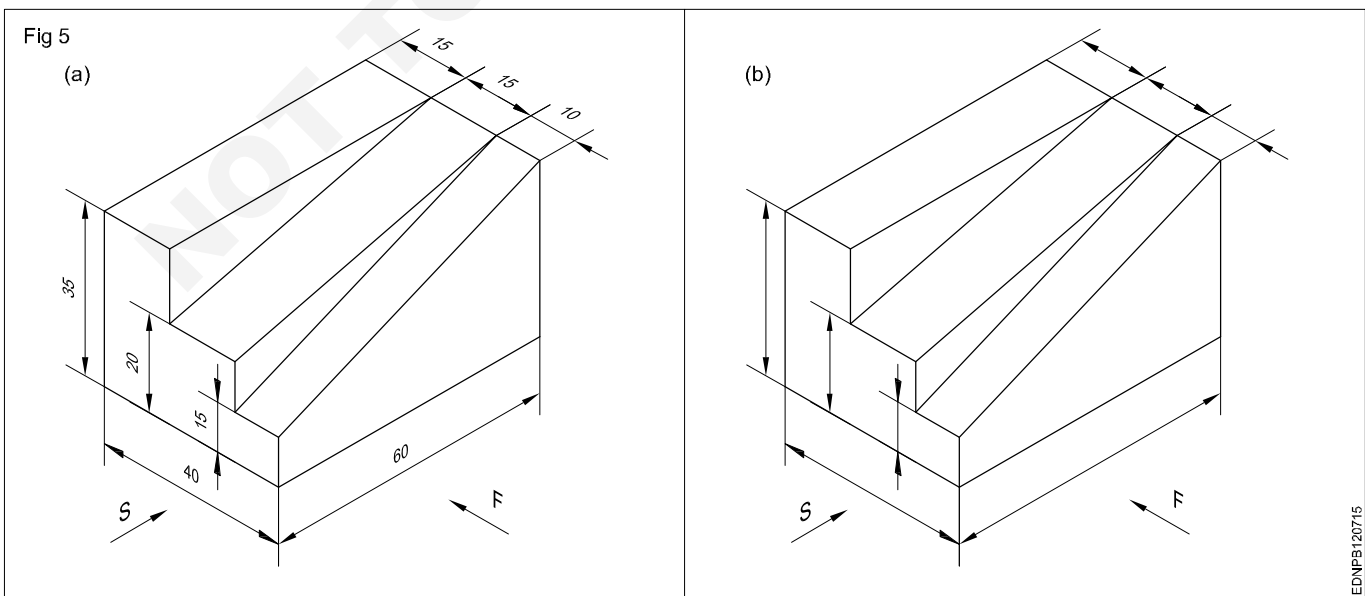
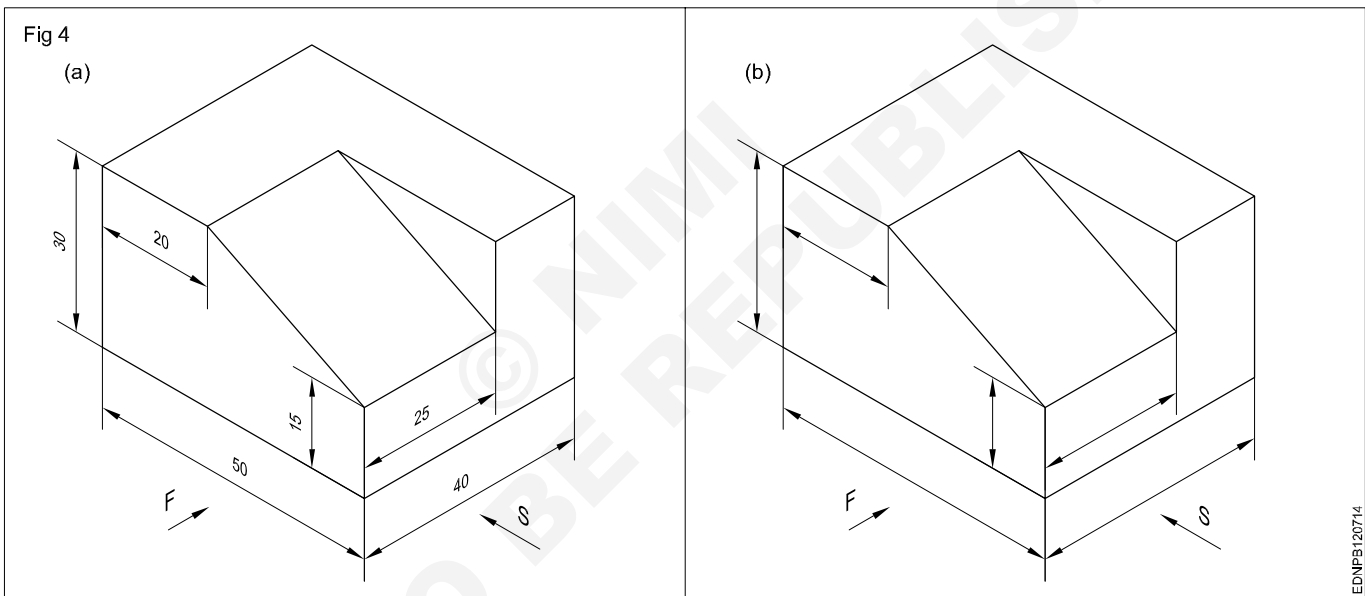
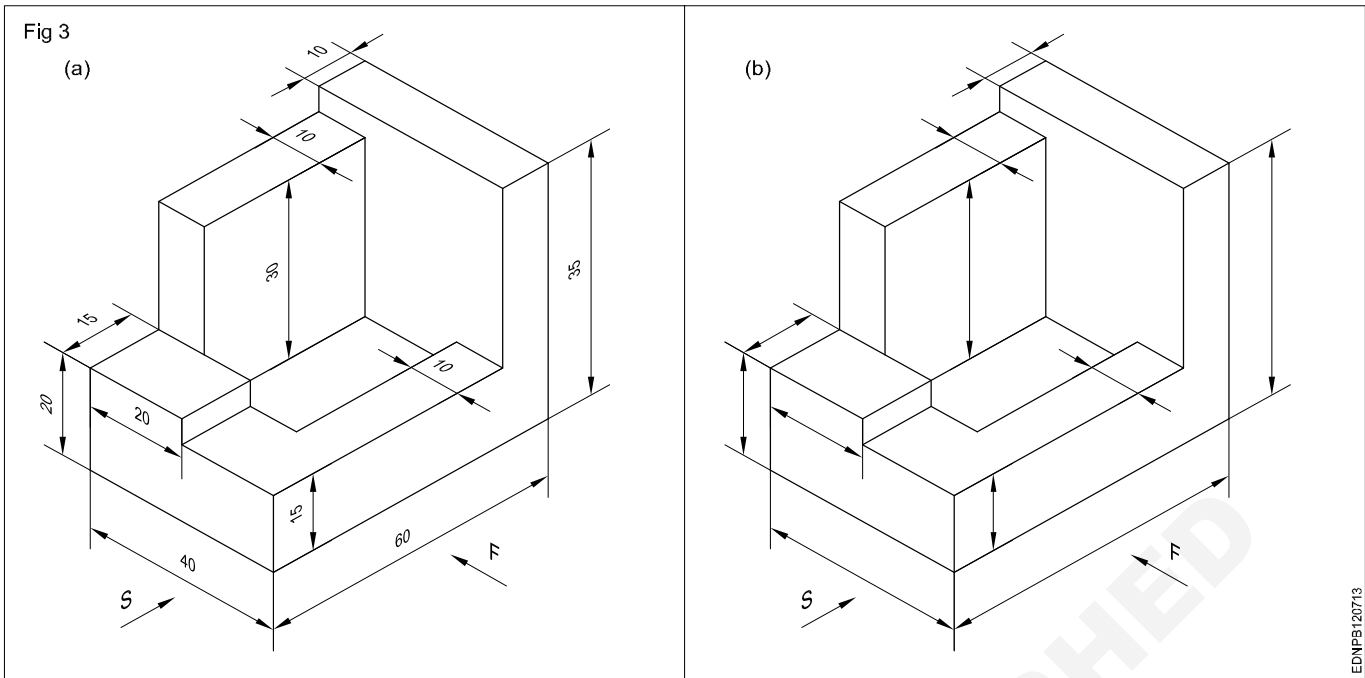

Fig 12 shows frustums and truncated pyramids. All items we use are solids. Their shapes may confirm individual geometrical solids like prisms, cones or other combinations.



Free hand drawing of - Transferring measurement from the given object to the free hand sketches





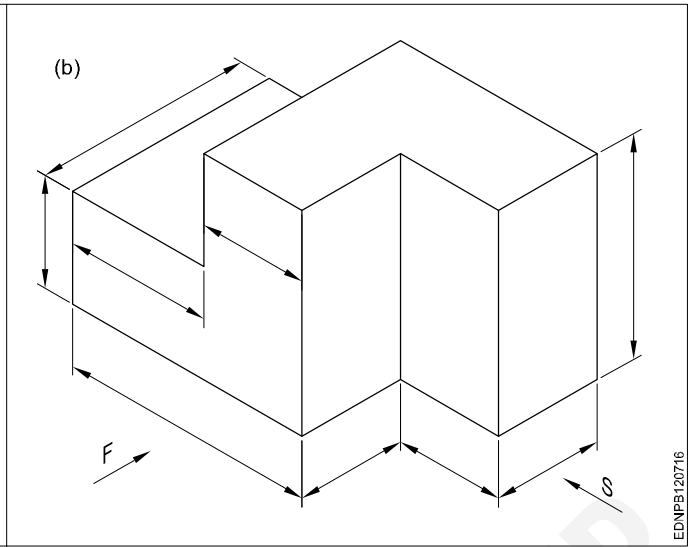
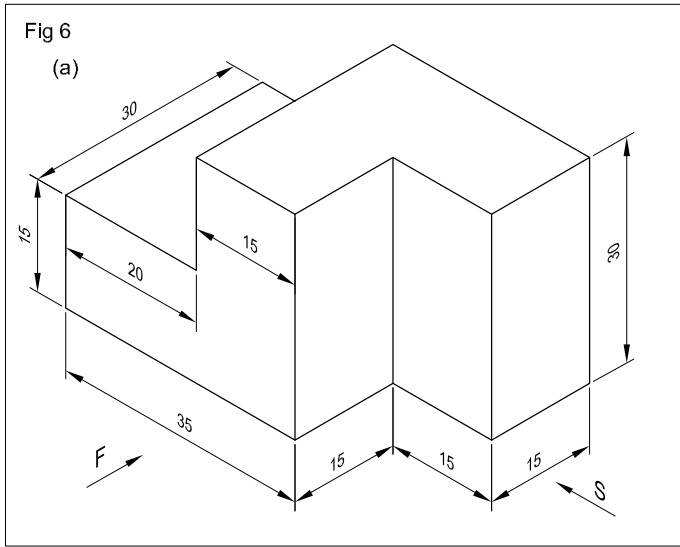

EDNIPB120716

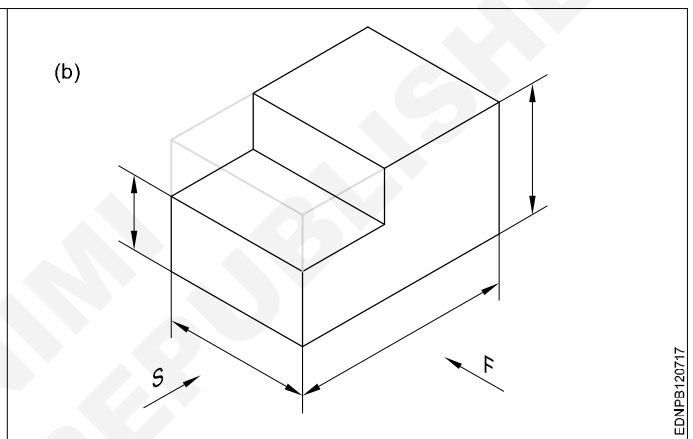
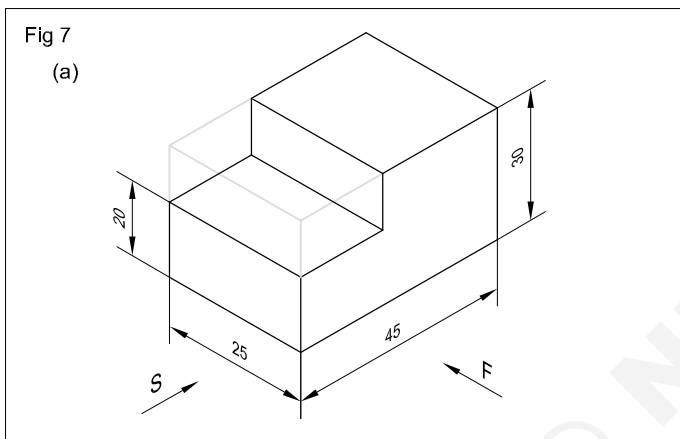

EDNIPB120717

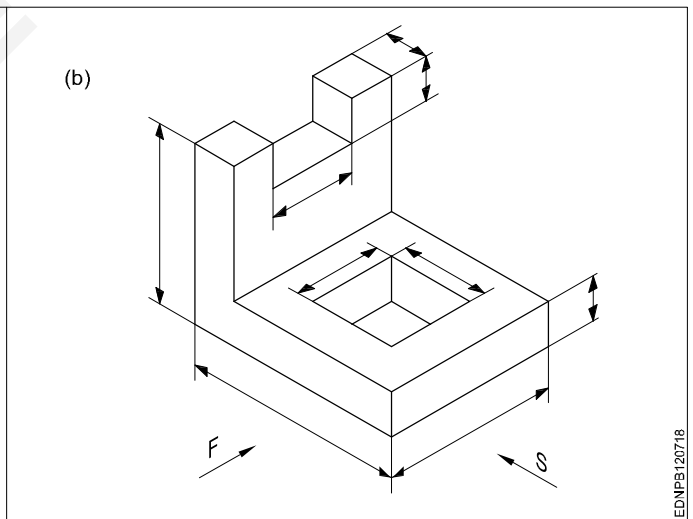
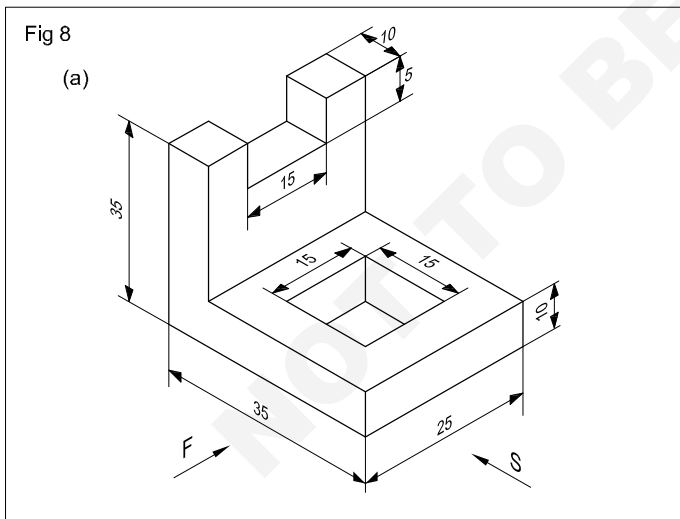

EDNIPB120718

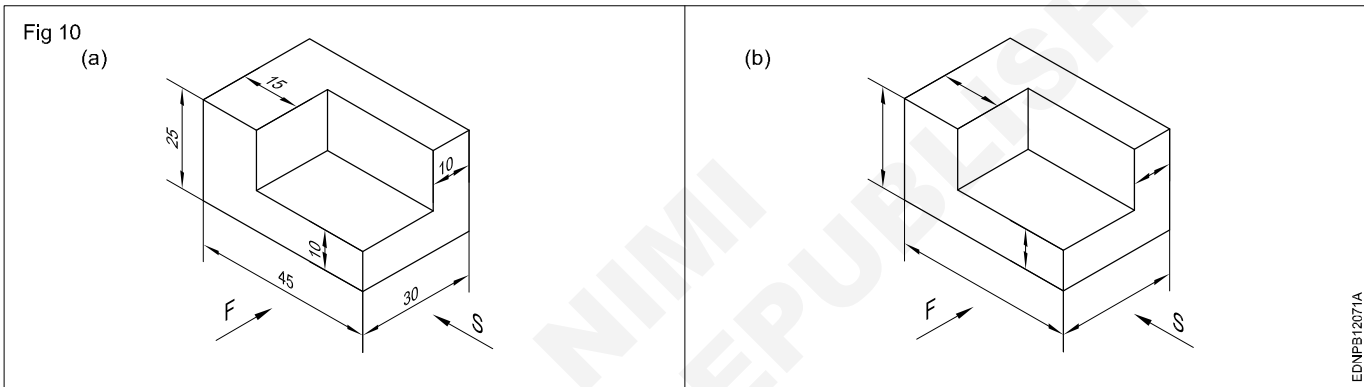
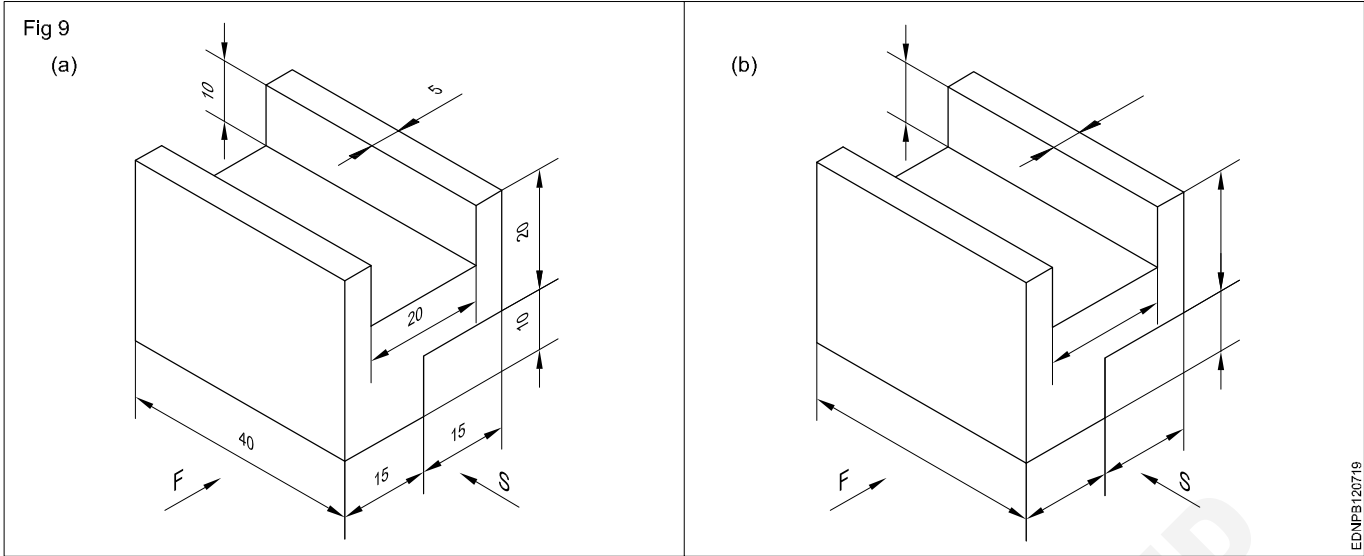

Free hand drawing of hand tools and measuring tools

Hand Tools

Files (Fig 1)

- a Curved cut file
- b Rasp cut file
- c Single cut file
- d Double cut file

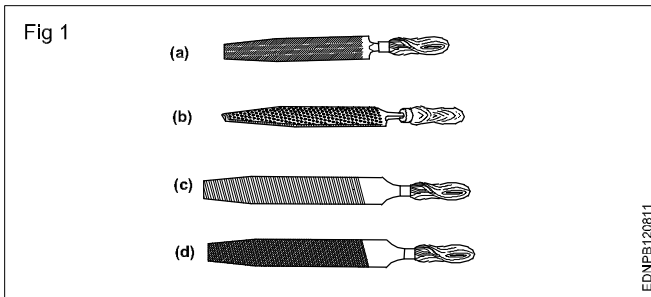

Hacksaw (Fig 2)

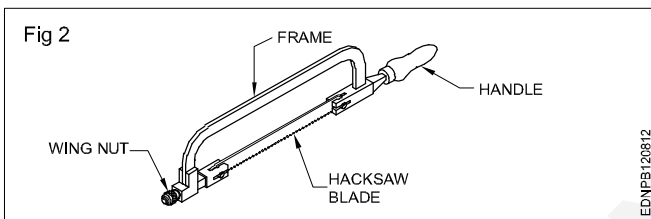

Ball pein hammer (Fig 3)

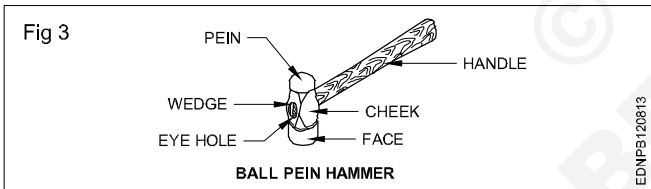

Chisel (Fig 4)

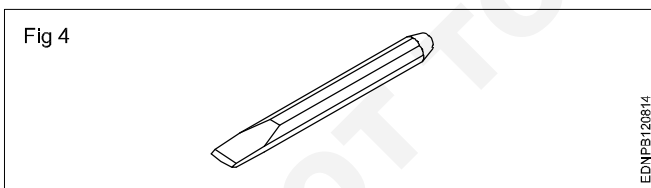

'C' clamp (Fig 5)

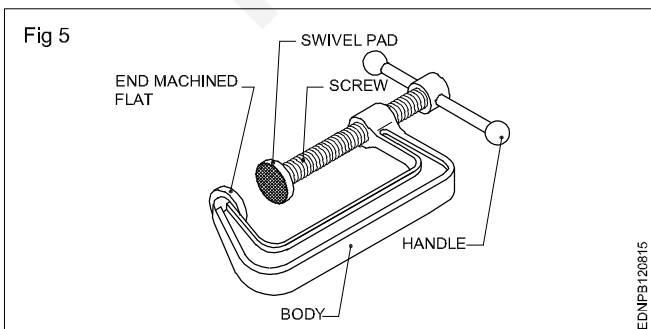

Bench vice (Fig 6)

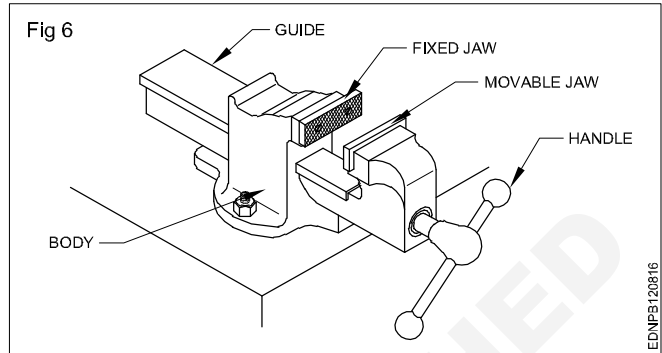

Cutting plier (Fig 7)

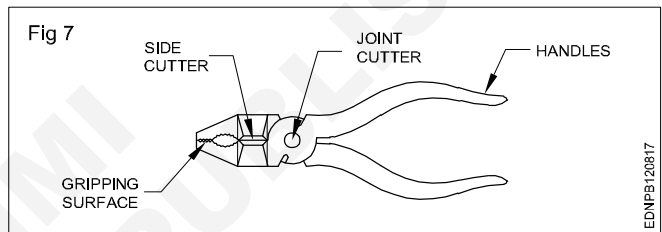

Open end spanner (Fig 8)

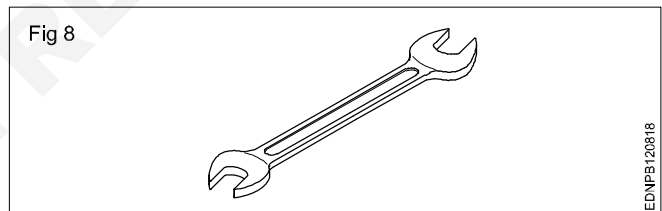

Hammers (Fig 9)

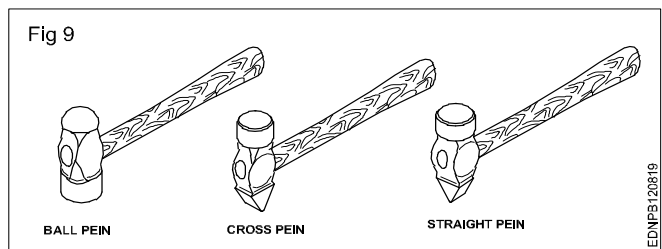

Measuring Tools

Steel rule (Fig 10)

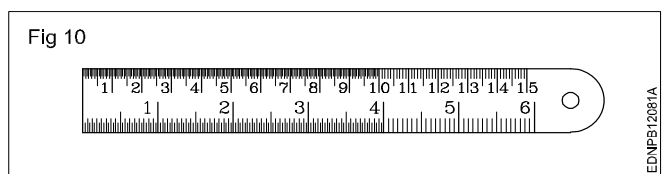

Try square (Fig 11)

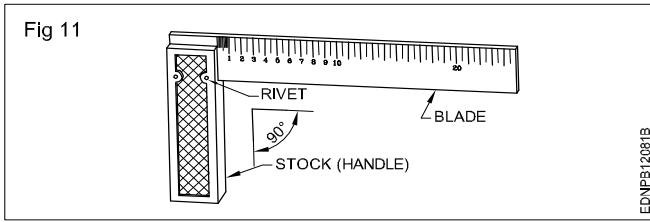

Screw driver (Fig 12)

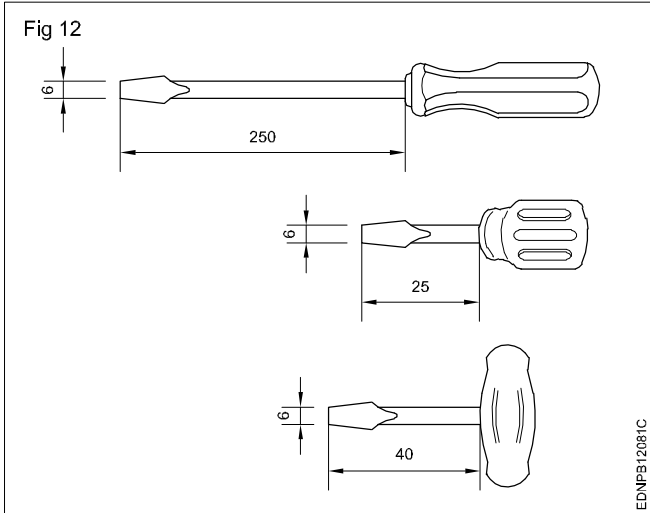

Ratchet brace (Fig 13)

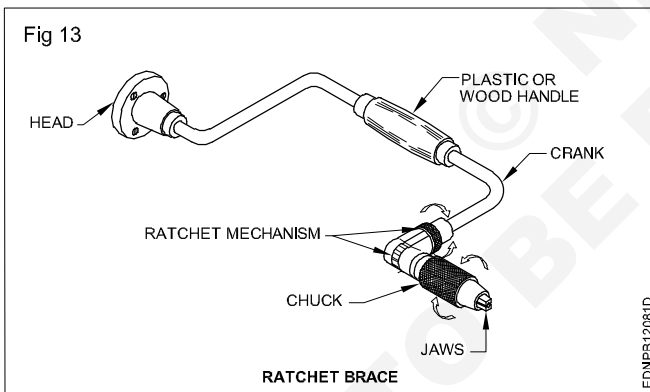

Face wrench (Fig 14)

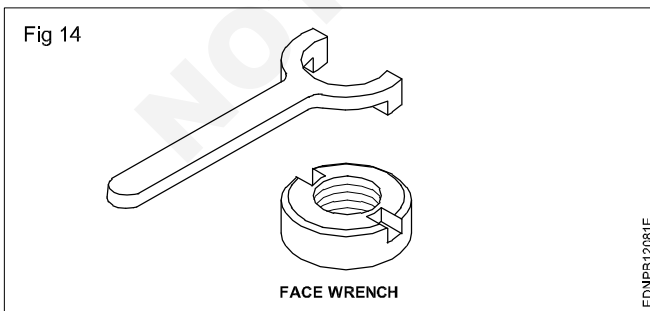

Hook wrench (Fig 15)

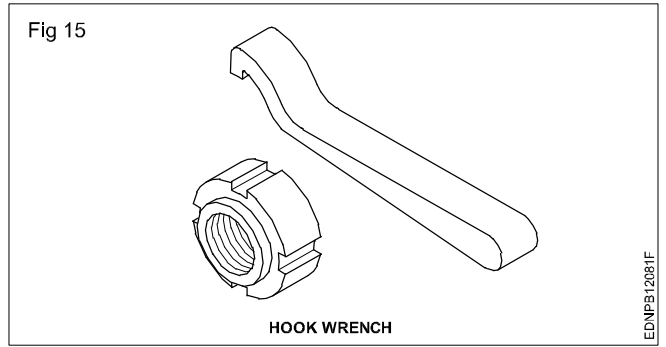

Spade (Fig 16)

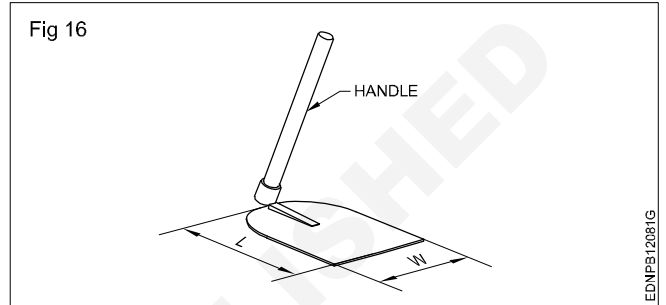

Pick axe (Fig 17)

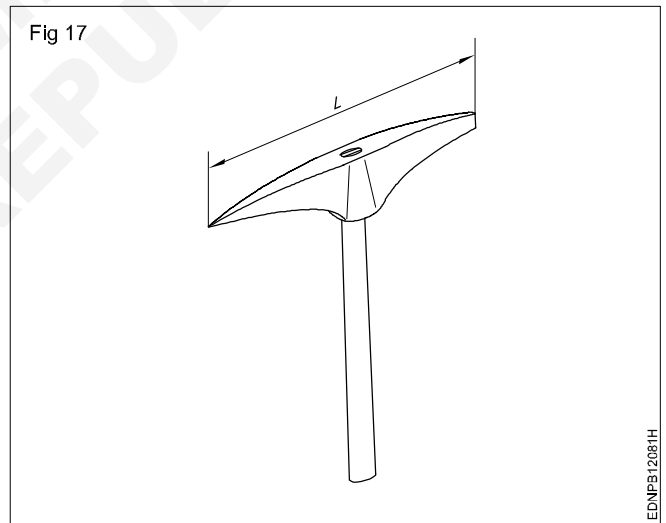

Mortar pan (Fig 18)

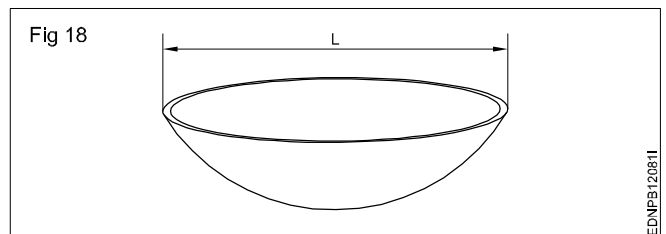

Blocklaying trowel (Fig 19)

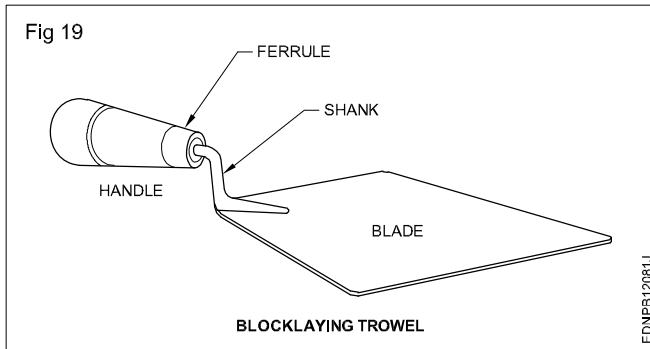

Jointing board (Fig 20)

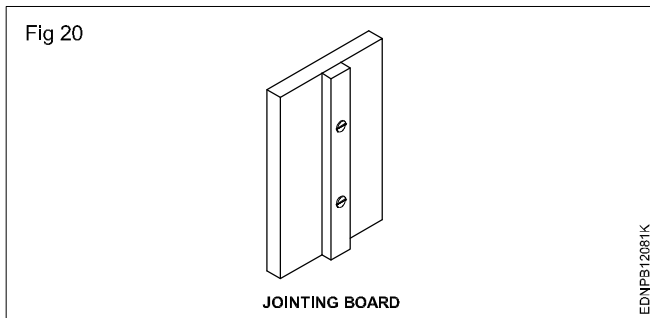

Steel square (Fig 21)

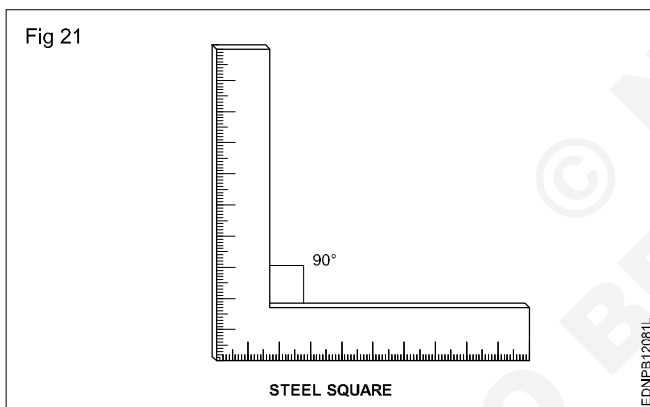

Line and pins (Fig 22)

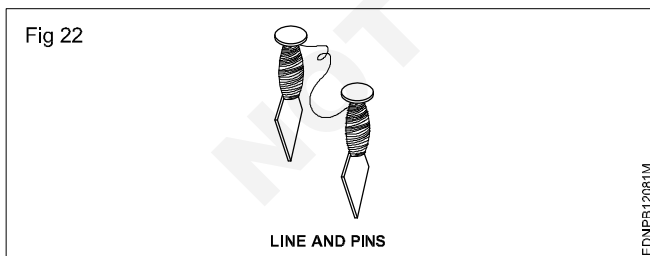

Chain pipe vice (Fig 23)

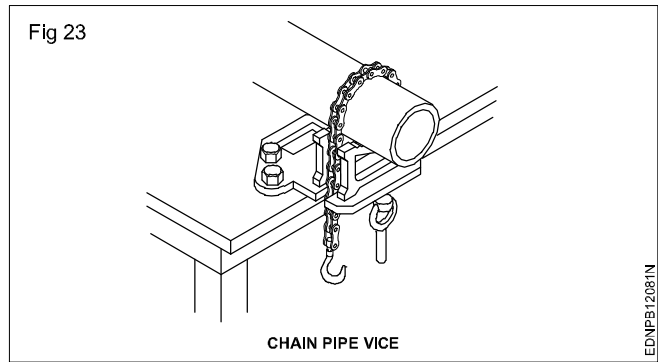

Pipe cutter (Fig 24)

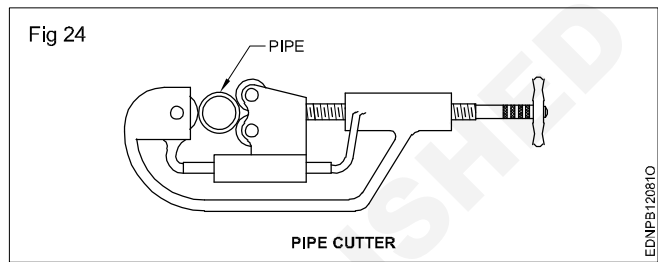

Multi wheel chain pipe cutter (Fig 25)

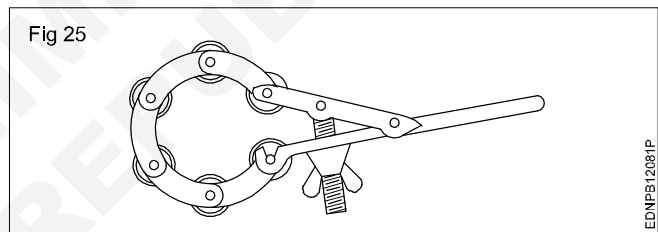

Accurate tube bender (Fig 26)

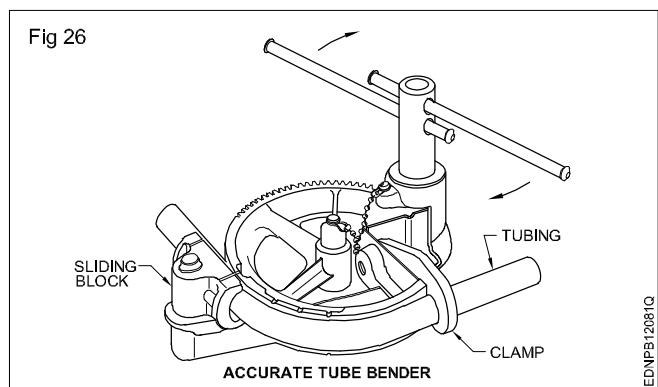

Pinch-off tool (Fig 27)

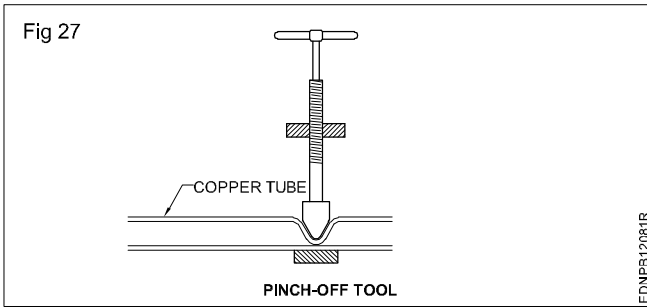

Rawl plug tool (Fig 31)

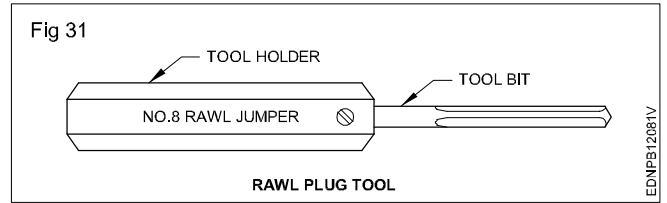

Mallet (Fig 28)

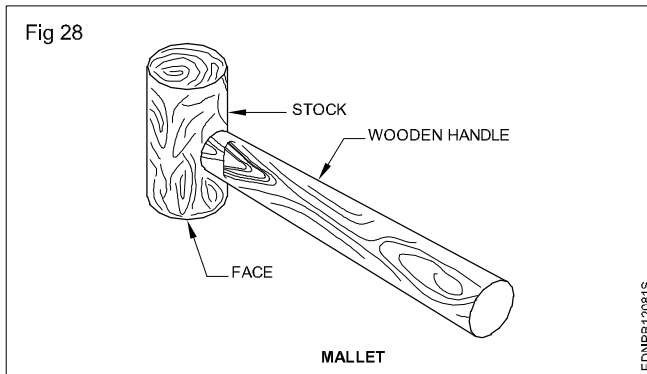

Pipe vice (Fig 32)

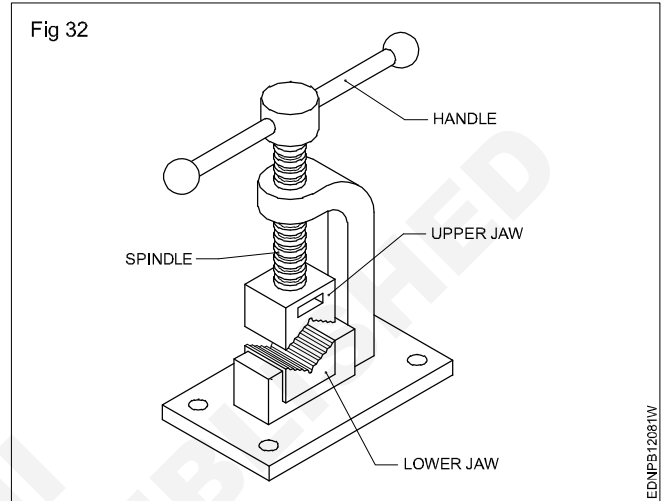

Electric drilling machine (Fig 29)

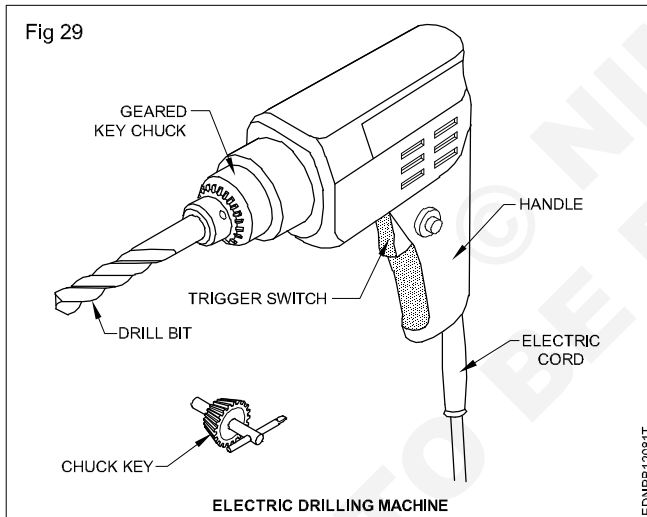

Chain pipe wrench (Fig 33)

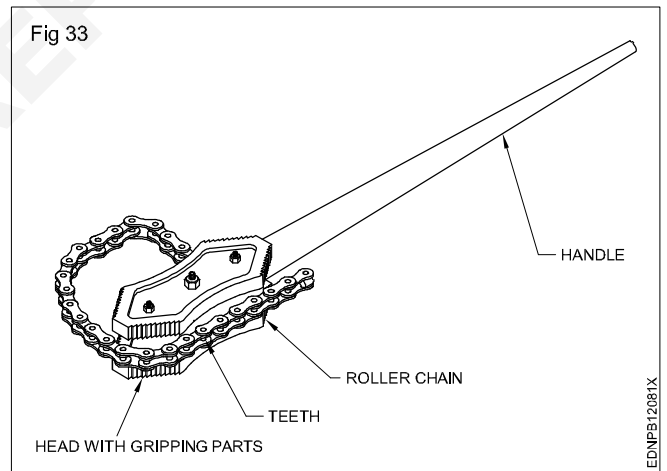

Hand drill (Fig 30)

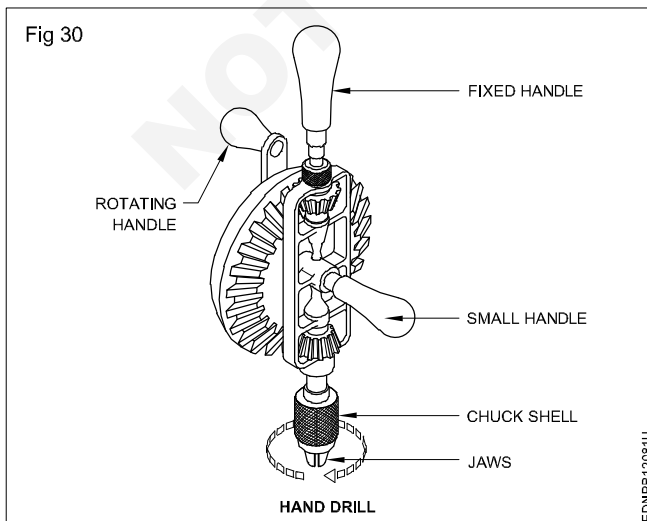

Die stock (Fig 34)

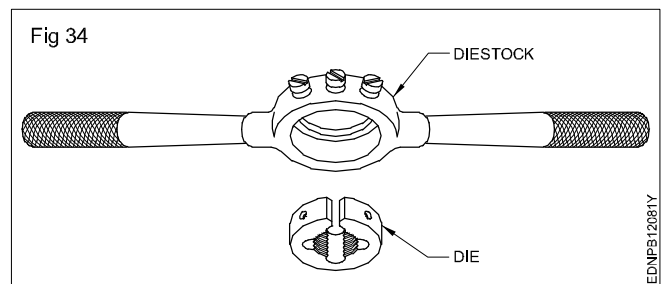

Straight edge (Fig 35)

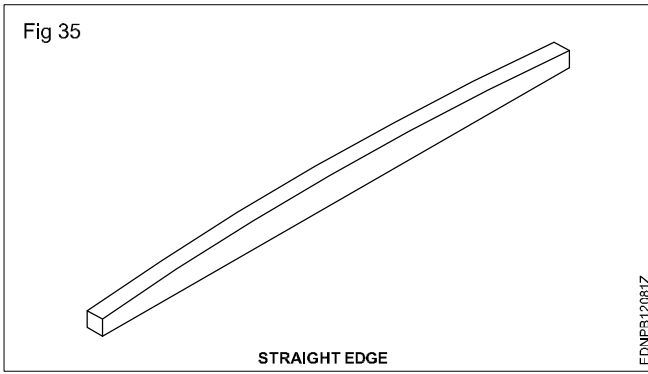

Boat level Spirit level (Fig 37)

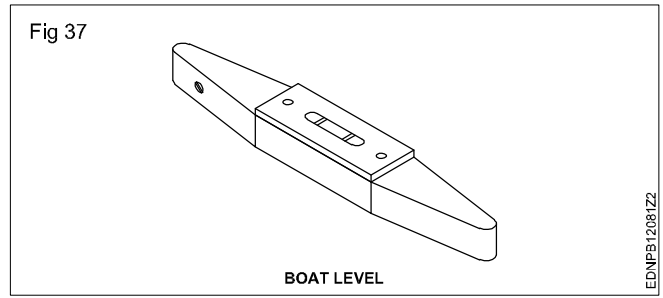

Spirit level (Fig 36)

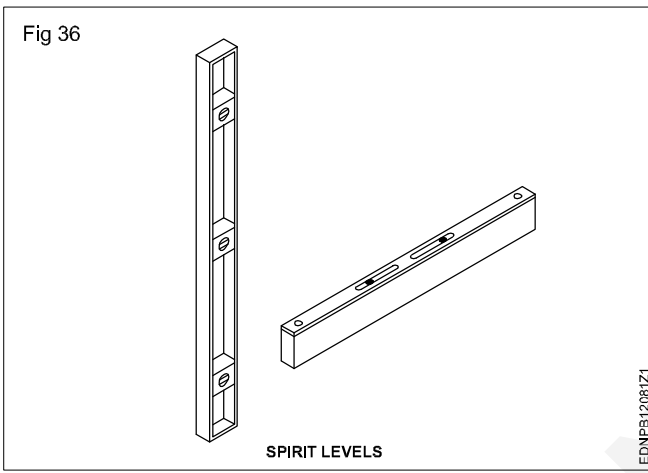

Plumb bob (Fig 38)

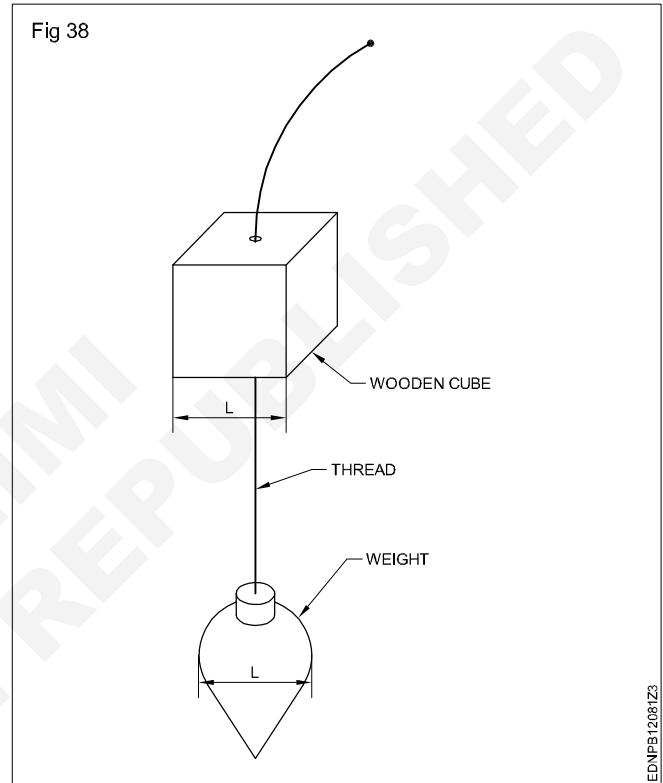

Drawing of geometrical figures - Angle & triangle

Angles: Angle is the inclination between two straight lines meeting at a point or meeting when extended. AB and BC are two straight lines meeting at B. The inclination between them is called an angle. The angle is expressed in degrees or radians.

Concept of a degree: When the circumference of a circle is divided into 360 equal parts and radial lines are drawn through these points, the inclination between the two adjacent radial lines is defined as one degree. Thus a circle is said to contain 360° . (Fig 1)

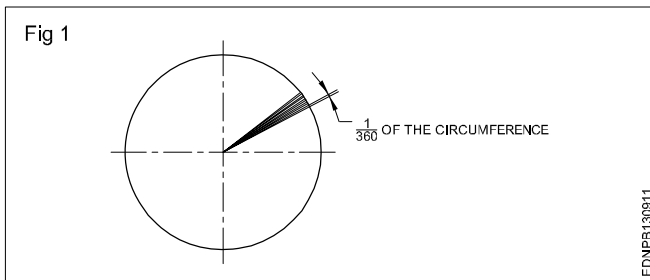

Acute angle: An angle that is less than 90° is called an acute angle. (Fig 2)

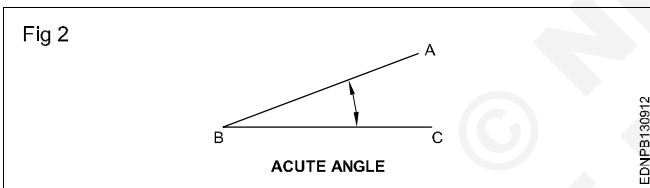

Right angle: The angle between a reference line and a perpendicular line is called a right angle. (Fig 3)

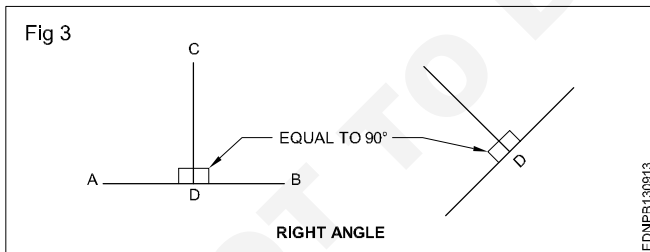

Obtuse angle: This refers to an angle between 90° and 180° . (Fig 4)

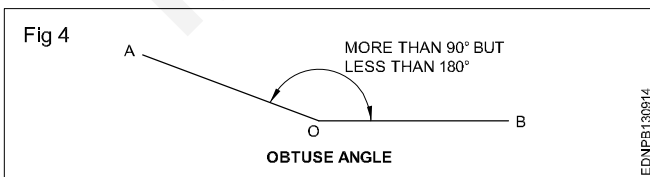

Straight angle: This refers to an angle of 180° . This is also called the angle of a straight line. (Fig 5)

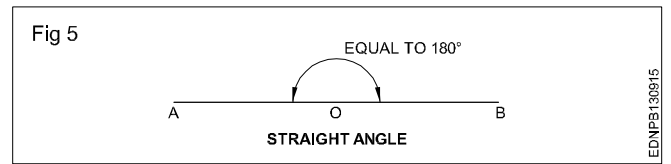

Reflex angle: It is the angle that is more than 180° , but less than 360° . (Fig 6)

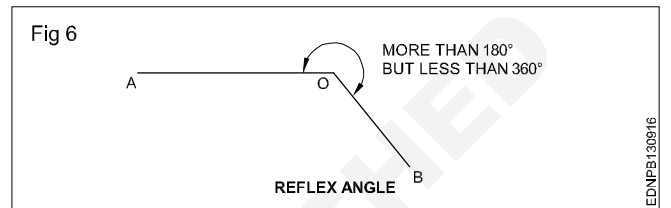

Adjacent angles: These are the angles lying on either side of a line. (Fig 7)

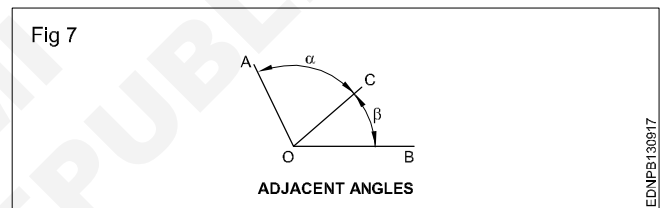

Complementary angles: When the sum of the two angles is equal to 90° , angle POQ + angle QOR = 90° angle POQ and angle QOR are complementary angles to each other. (Fig 8)

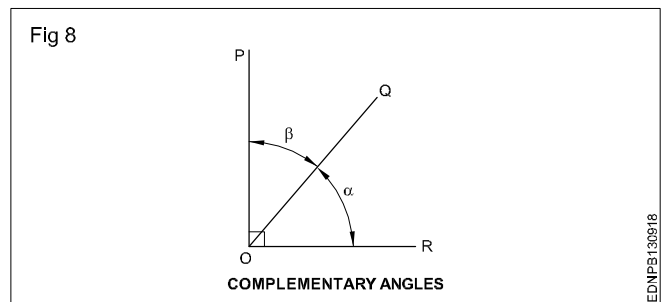

Supplementary angle: When the sum of the two adjacent angles is equal to 180° , for example, angle SOT + angle TOY = 180° , angle SOT and angle TOY are supplementary angles to each other. (Fig 9)

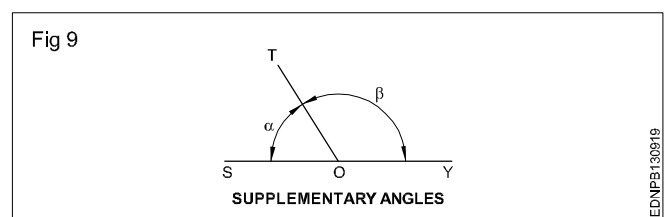

Triangle - different types

Triangle is a closed plane figure having three sides and three angles. The sum of the three angles always equals to 180° .

To define a triangle, we need to have a minimum of three measurements as follows:

- 3 sides or
- 2 sides and one angle or
- 2 angles and one side

Types of triangles

1 Equilateral triangle is a triangle having all the three sides equal. Also all the three angles are equal (60°). (Fig 1)

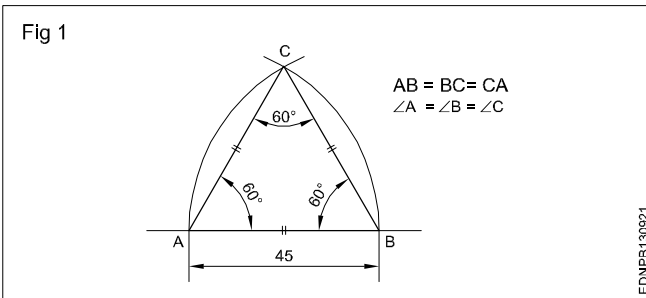

2 Isosceles triangle has two of its sides equal. The angles opposite the two equal sides are also equal. (Fig 2)

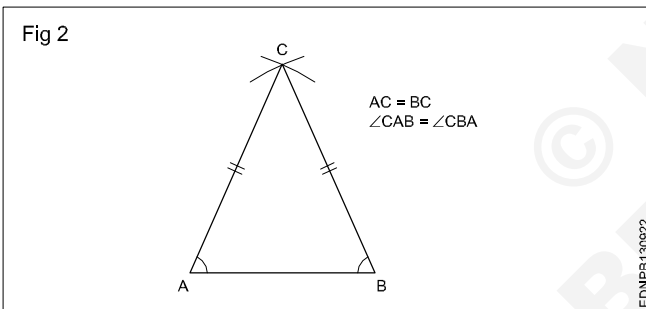

3 Scalene triangle has all three sides unequal in length. All three angles are also unequal. (Fig 3)

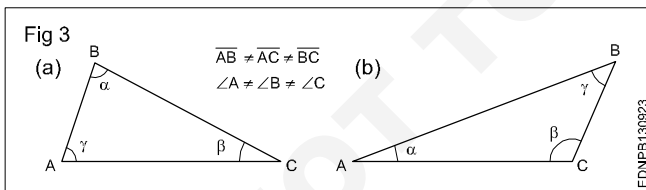

4 A right-angled triangle is one in which one of the angles is equal to 90° (Right angle). The side opposite the right angle is called the hypotenuse. (Fig 4)

5 An Acute angled triangle is one in which all the three angles are less than 90° . (Fig 5)

6 Obtuse angled triangle has one of the angles more than 90° . (Fig 6)

The sum of the three angles in any triangle is equal to 180° .

The sum of any two sides is more than the third side.

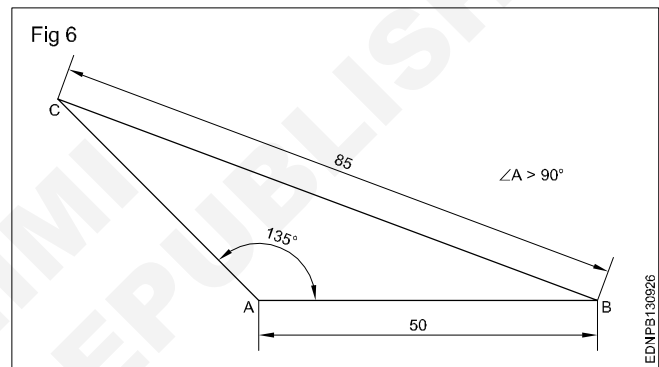
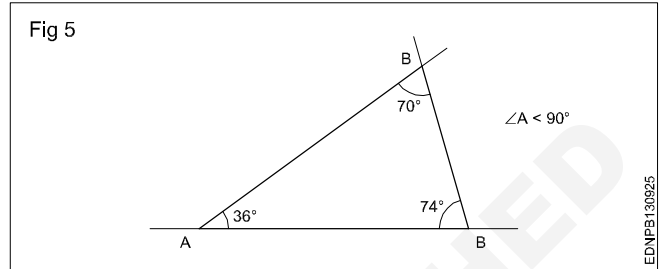
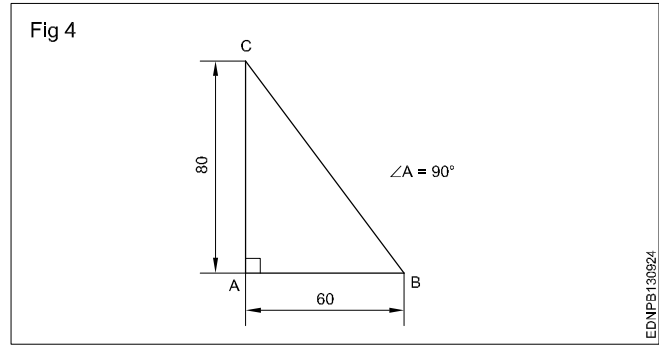

Procedure to draw the triangle

1 Equilateral triangle (Fig 1) $AB = BC = CA = 35$ mm.

- Draw a line and mark AB 35 mm side of the triangle.
- Draw radius from centre A and B, arcs cutting mark at C (Fig 1).
- Join CA and CB.
- ABC is a required triangle.

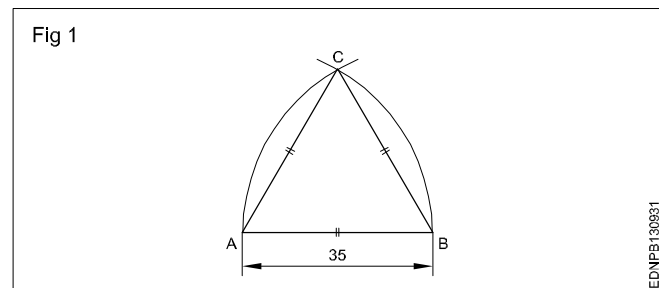

2 Isosceles triangle : $AB = AC = 60$ mm & $\angle BAC = 40^\circ$.

- Draw the side AB equal to 60 mm. 'A' as the centre, draw an arc of radius AB.
- Draw a line AC at 40° to AB.
- Join BC to form the triangle ABC. (Fig 2)

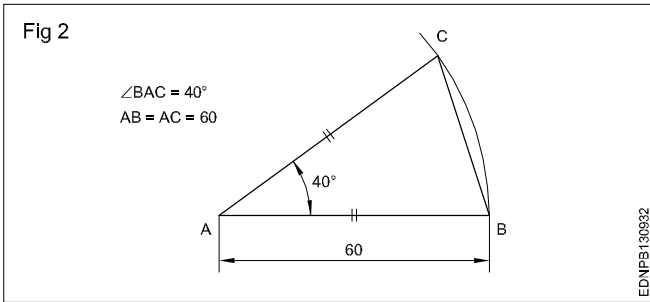

Exercise

- 1 **Scalene triangle: $AB = 30$ mm, $AC = 55$ mm & $BC = 35$ mm. (Fig 1)**

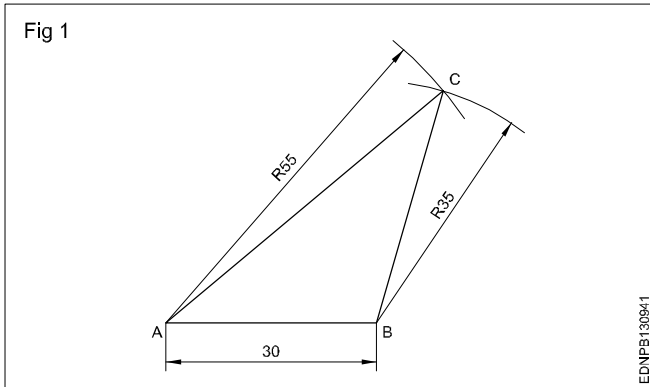

- 2 **Scalene triangle: $AB = 70$ mm. (Fig 2)**

$\angle ABC = 40^\circ$ & $\angle BAC = 110^\circ$

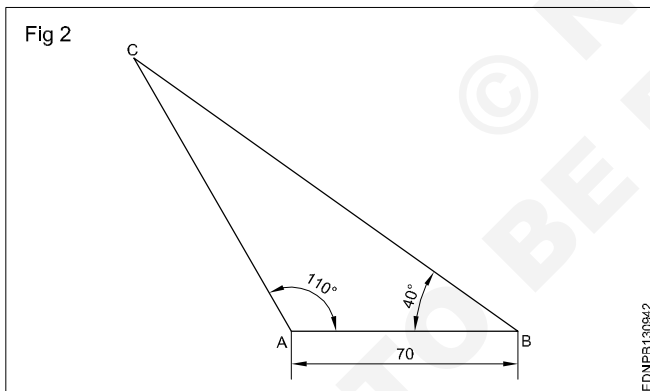

- 3 **Right angled triangle: $AB = 60$ mm, $BC = 45$ mm. (Fig 3)**

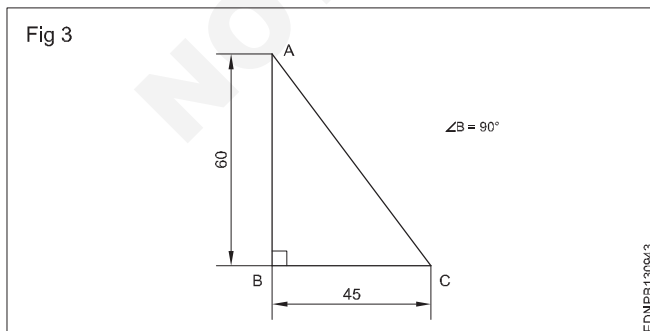

- 4 **Draw a triangle when one side and 2 angles being given in Fig 4.**

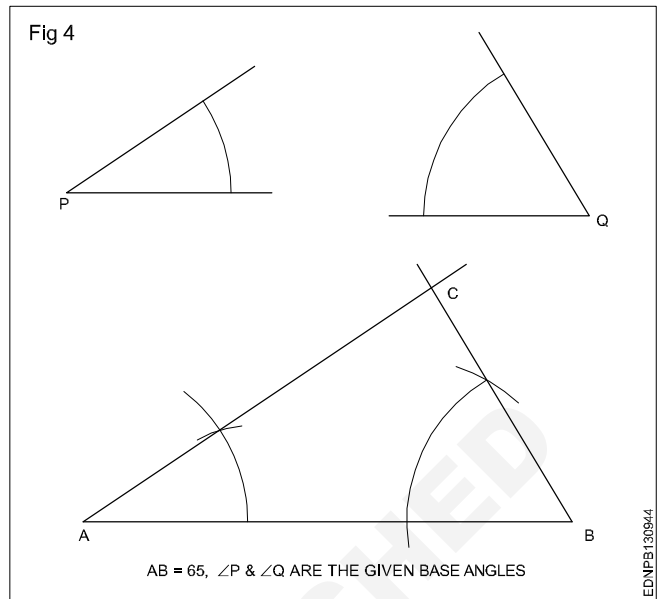

- 5 **Draw a right angled triangle when the base and hypotenuse being given in Fig 5.**

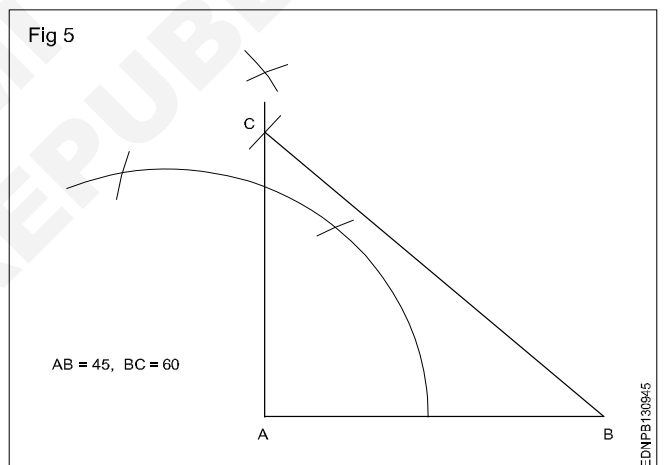

- 6 **Draw a triangle with the altitude and two sides being given in Fig 6.**

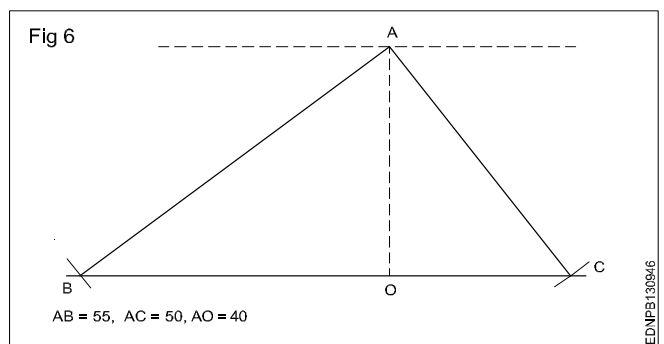

Drawing of geometrical figures - Circle

Circle: Circle is a plane figure bounded by a curve, formed by the locus of a point which moves so that it is always at a fixed distance from a stationary point the "Centre".

Radius: The distance from the centre to any point on the circle is called the "Radius".

Diameter: The length of a straight line between two points on the curve, passing through the centre is called the "Diameter". (D: Dia or d) It is twice the radius.

Circumference: It is the linear length of the entire curve, equal to πD .

Arc: A part of the circle between any two points on the circumference or periphery is called an 'Arc'.

Chord: A straight line joining the ends of an arc is called the chord. (Longest chord of the circle is the diameter)

Segment: A part of the circle or area bound by the arc and chord is the segment of the circle.

Sector: It is the part of a circle bounded by two radii (plural of radius) meeting at an angle and an arc.

Quadrant: Part of a circle with radii making 90° with each other is a quadrant (one-fourth of the circle).

Half of the circle is called a semi-circle.

Tangent: The tangent of a circle is a straight line just touching the circle at a point. It does not cut or pass through the circle when extended.

Fig 1 shows all the above elements.

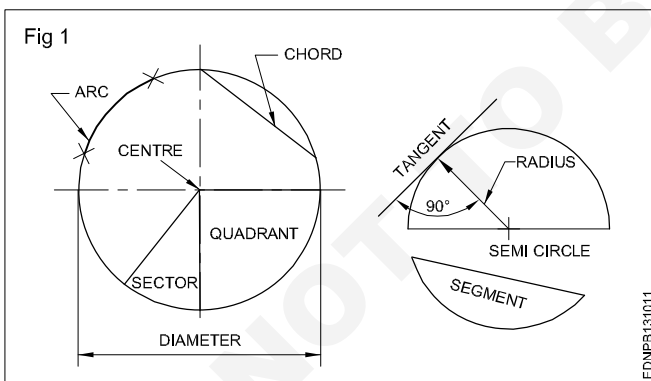

Concentric circles: When two or more circles (drawn) have a common centre, they are called concentric circles. Ball-bearing is the best example of concentric circles. (Fig 2)

Eccentric circles: Circles within a circle but with different centres are called eccentric circles. (Fig 3)

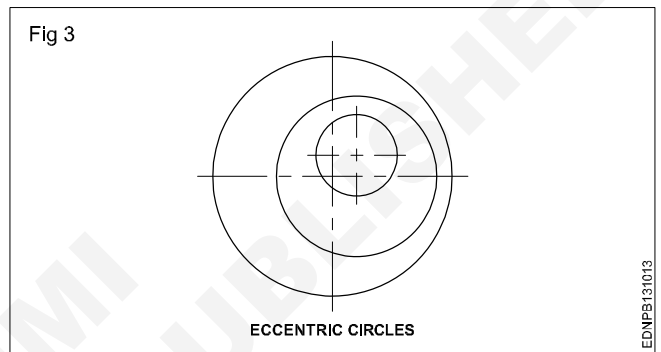
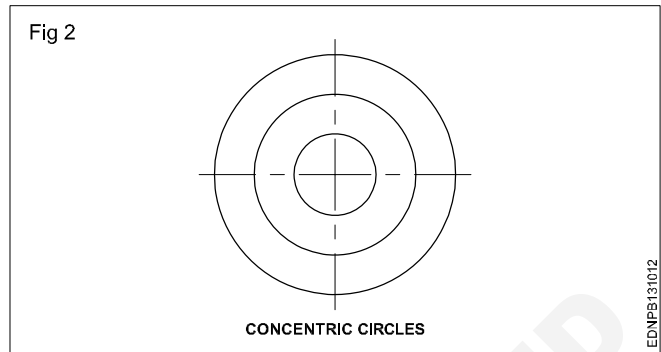

Circle and Arcs

Exercise

1 Draw a tangent to a given circle of ϕ 50 mm at any point 'P' on it. (Fig 1)

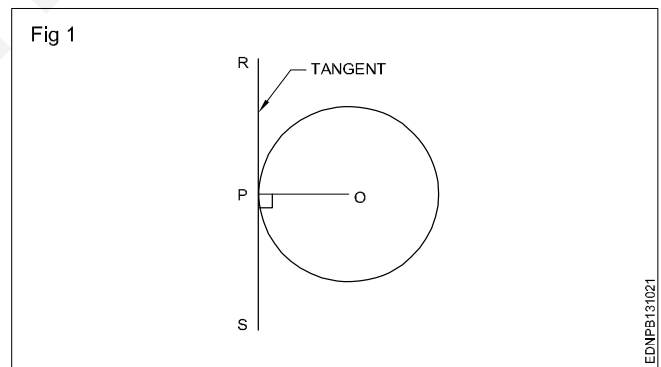

2 Draw a loop of 3 circles pattern. (Fig 2)

Draw any line MN and mark points A, B and C. So that AB = 20 mm and BC = 25 mm.

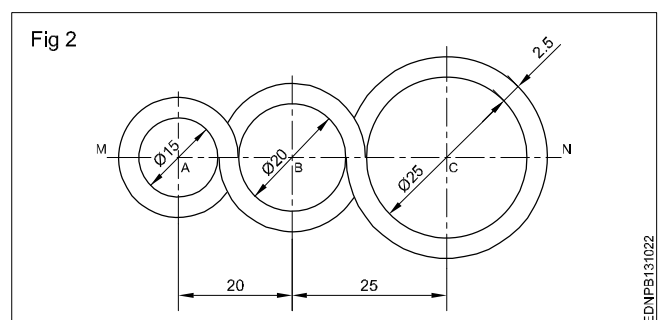

3 3 Draw three circles tangential to each other if centres A, B & C are given. (Fig 3)

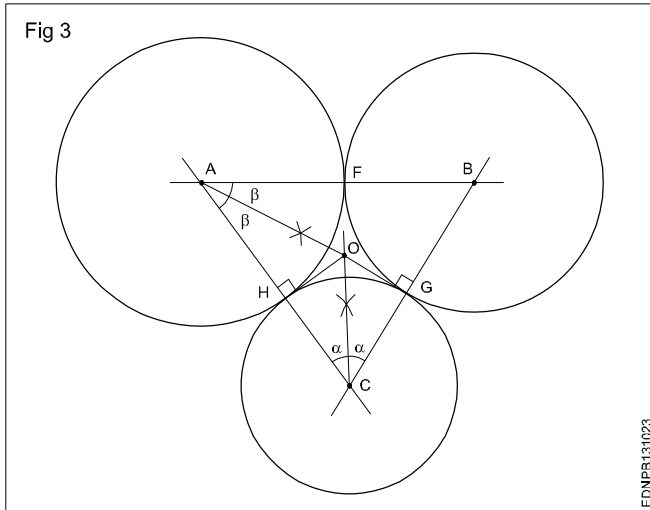

4 Draw external tangents to circles of dia 40 and 30 and centre distance 60 mm. (Fig 4)

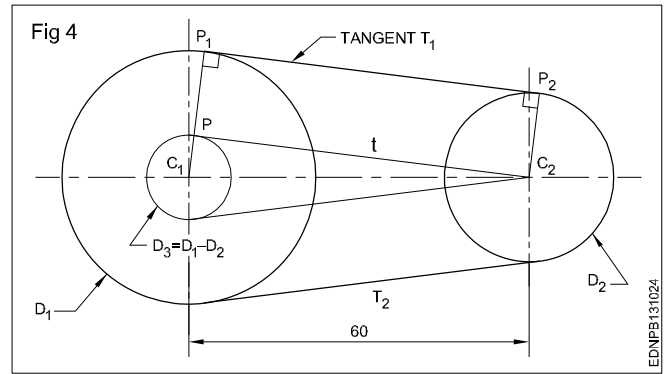

5 Draw internal tangents to circles of the same diameter 40 each and a centre distance of 60 mm. (Fig 5)

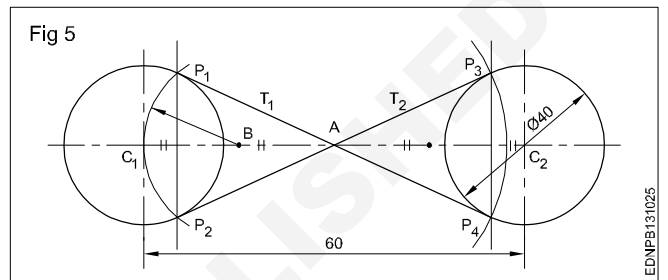

Drawing of geometrical figures - Square, rectangle and parallelogram

A quadrilateral is a plane figure bounded by four sides and four angles. The sum of the four angles in a quadrilateral is (interior angles) equal to 360° . The side joining opposite corners is called diagonal. To construct a quadrilateral out of four sides, four angles and two diagonals a minimum of five dimensions are required of which two must be sides. Quadrilaterals are also referred as Trapezium. (Fig 1)

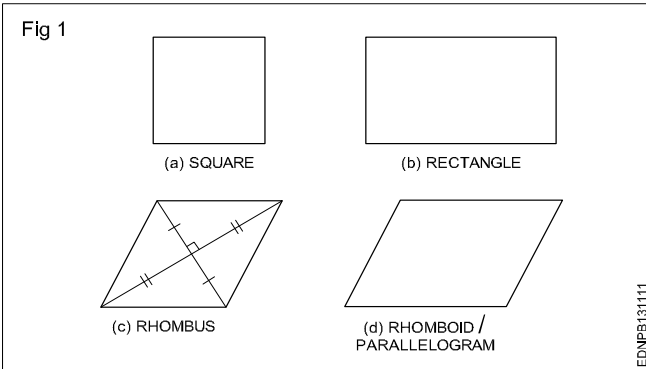

Types of quadrilaterals (Fig 1)

- Square
- Rectangle
- Rhomboid/Parallelogram

Square: In a square all the four sides are equal and its four angles are at right angles. The two diagonals are equal and perpendicular to each other.

Rectangle (Fig 2): In a rectangle, opposite sides are equal and parallel and all four angles are right angles.

Fig 2 shows a rectangle ABCD, Sides $AB = DC$ and $BC = AD$. Diagonals AC and BD are equal. Diagonals are not bisected at right angles.

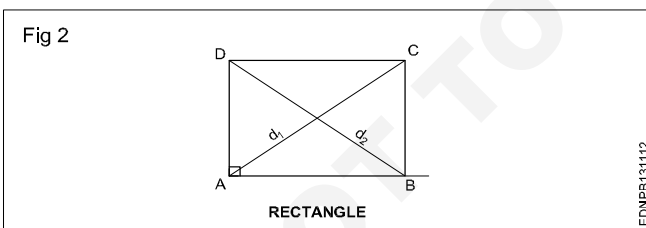

Rhomboid/Parallelogram (Fig 3): In a parallelogram, opposite sides are equal and parallel. Opposite angles are also equal. Diagonals are not equal but bisect each other.

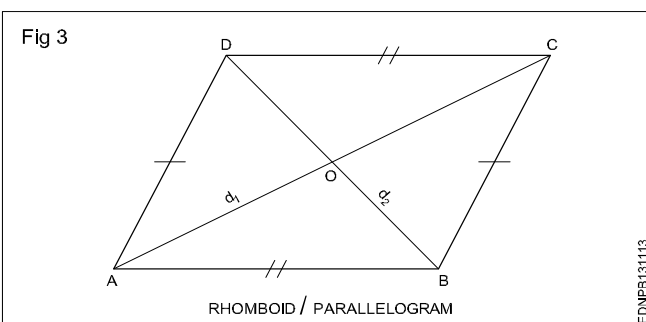

Procedure to draw the square, rectangle and parallelogram

Square

1 **1st method (Fig 1):** A square of side 50 mm by erecting perpendicular using compass and 45° set square.

Draw a line 50mm. 'A' as centre draw an arc of convenient radius. Same arc cut and mark as PQR. Draw a line perpendicular, mark 50mm and make a square as shown in figure.

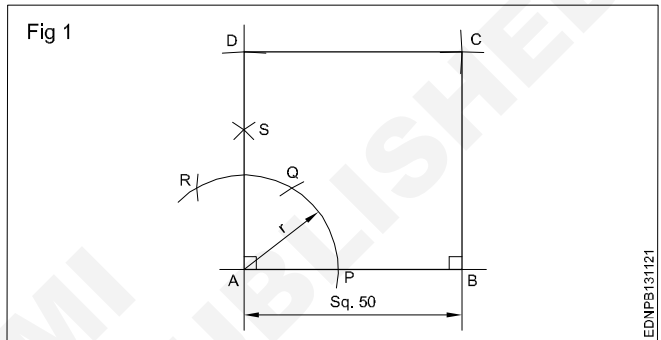

2 **2nd method (Fig 2):** A square of side 60 mm using 45° setsquare and compass.

Draw a horizontal line $AB = 60$ mm. From point 'A' & 'B' using 45° setsquare draw diagonal and circle of radius OA with centre 'O'. Join points AD, DC & CB to complete the required square.

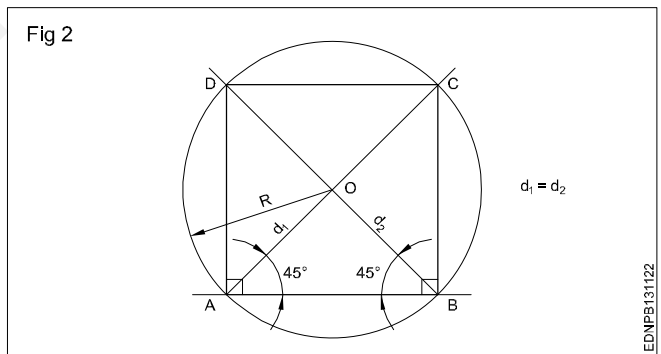

3 **3rd method (Fig 3):** A square of side 60 mm long by erecting perpendicular and also using 45° setsquare. Mark AD, BC and join ABCD to get the required square.

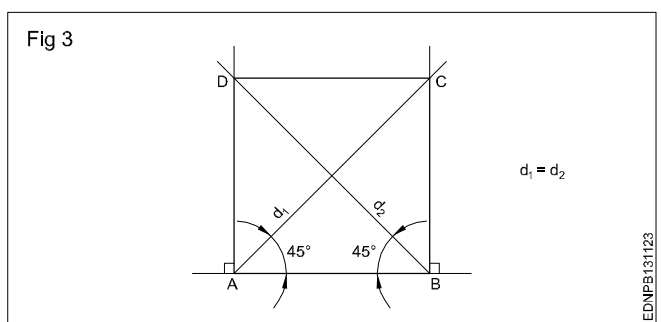

4 Square having diagonal 60 mm (Fig 4)

Draw horizontal and vertical centre lines intersect at 'O' and make a circle. Join all the points ABC&D to get the required square.

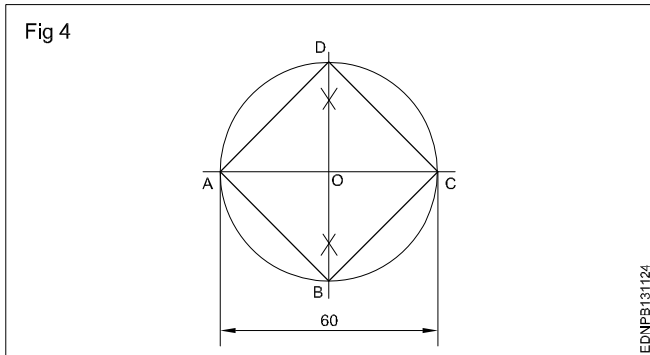

5 Rectangle (Fig 5)

Draw AB = 75 mm and side AD = 45 mm using setsquare and compass. Draw BC = 45 mm using setsquare and compass. Join ABCD to get the required rectangle.

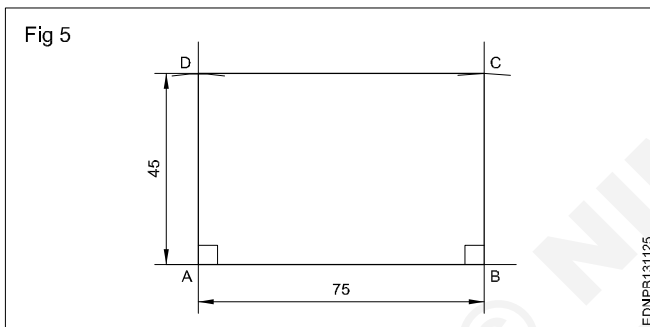

6 Rectangle - Diagonal - 60 mm and one side 20 mm 1st method (Fig 6a)

2nd method (Fig 6b)

ADBC is the required rectangle of side 20 mm and diagonal 60 mm by using setsquare and compass.

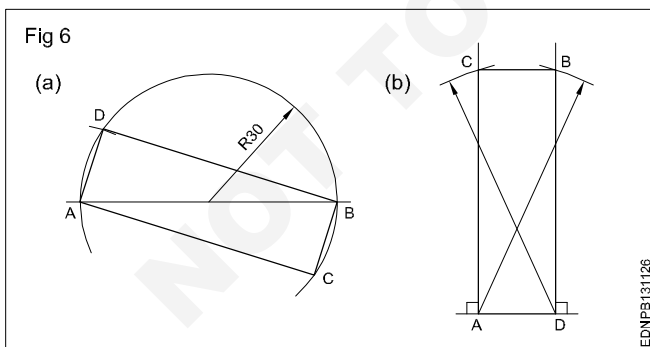

7 Parallelogram (Fig 7)

Sides = 75 mm and 40 mm, angle 50°

- Draw line AD equal to 40 mm and 50° angle to AB.
- 'D' as centre, draw an arc of radius equal to AB.
- 'B' as centre, draw an arc of radius equal to AD, upwards such that they meet at a point 'C'. Join ABCD to get the required parallelogram.

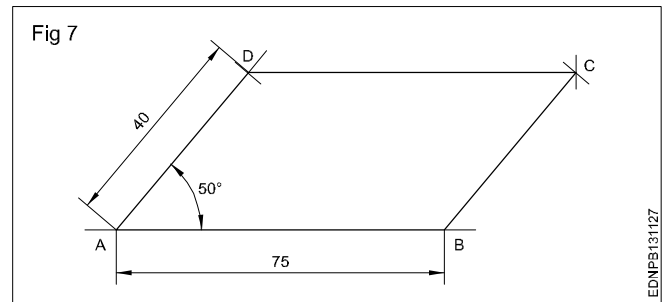

8 Parallelogram (Fig 8)

Parallelogram - Side AB = 60 mm

Diagonal AC = 90 mm $\angle ABC = 120^\circ$

- Draw a line AB = 60 mm. Draw a line from B to an angle 120° to AB.
- 'A' as centre with radius 90 mm, draw an arc cutting 120° line from 'B' at 'C'.
- 'C' as centre, radius = AB, draw an arc.
- 'A' as centre and BC as radius, draw another arc, both arcs meet at 'D'. Join AD and DC.

ABCD is the required parallelogram.

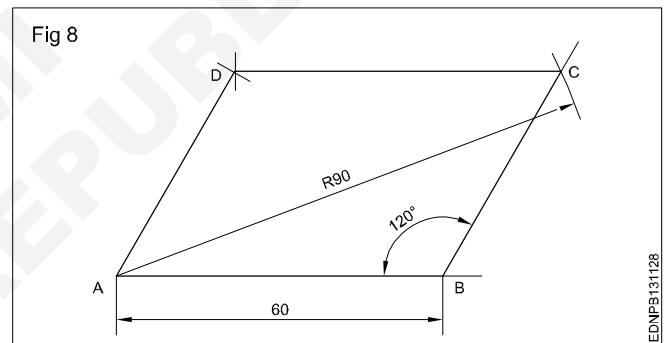

9 Parallelogram (Fig 9)

Sides AB = 55 mm, BC = 40 mm and vertical height = 30 mm.

- Draw the line AB = 55 mm long.
- 'A' and 'B' as centres and radius (R) 30 mm, draw arcs above the line.
- Draw a parallel tangential line to AB touching the arcs.
- 'A' and 'B' as centres, draw an arc of 40 mm radius cutting the line at 'D' and 'C'.

ABCD is the required parallelogram.

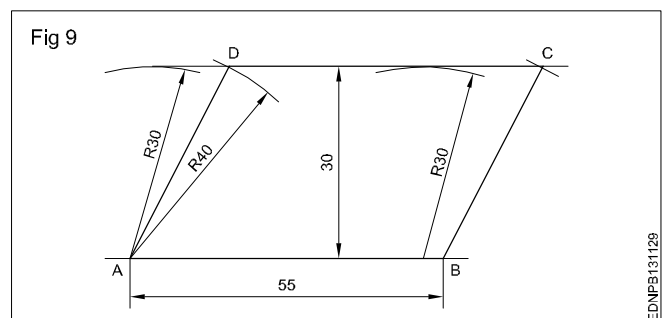

Reading of dimension and dimensioning practice - Dimensioning

Dimensioning - Types of arrow heads and leader line with text

Dimension line: These are thin continuous lines, terminated at ends by arrowheads, dots or oblique lines touching the extension line. (Fig 1)

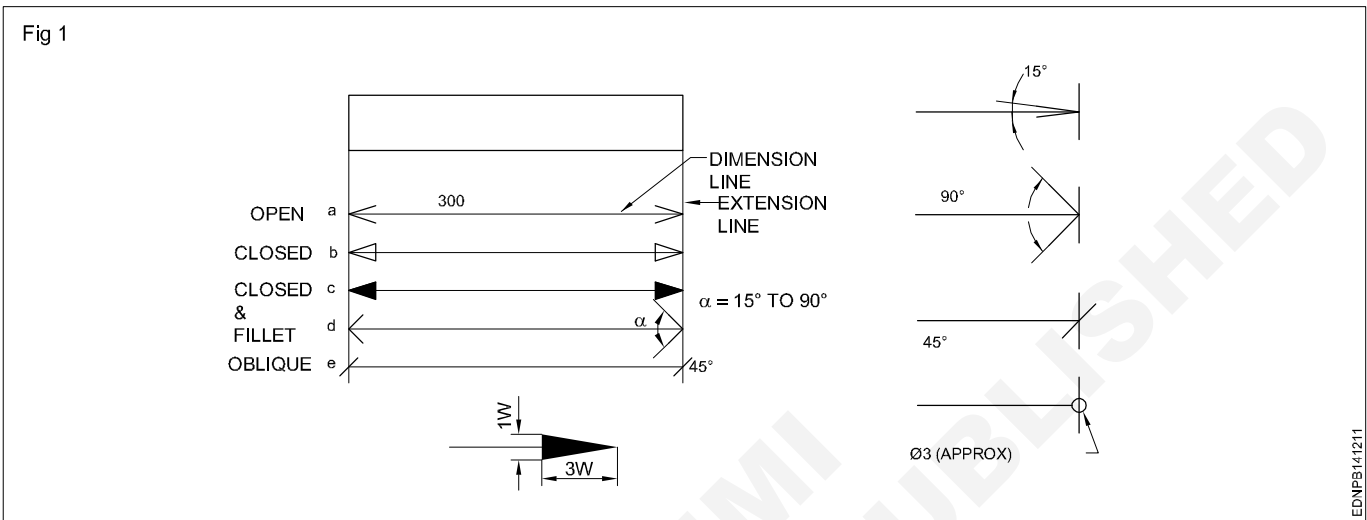

A dimension line may cut or cross another dimension line where there is no other way.

Dimension to the hidden lines be avoided. (Fig 2)

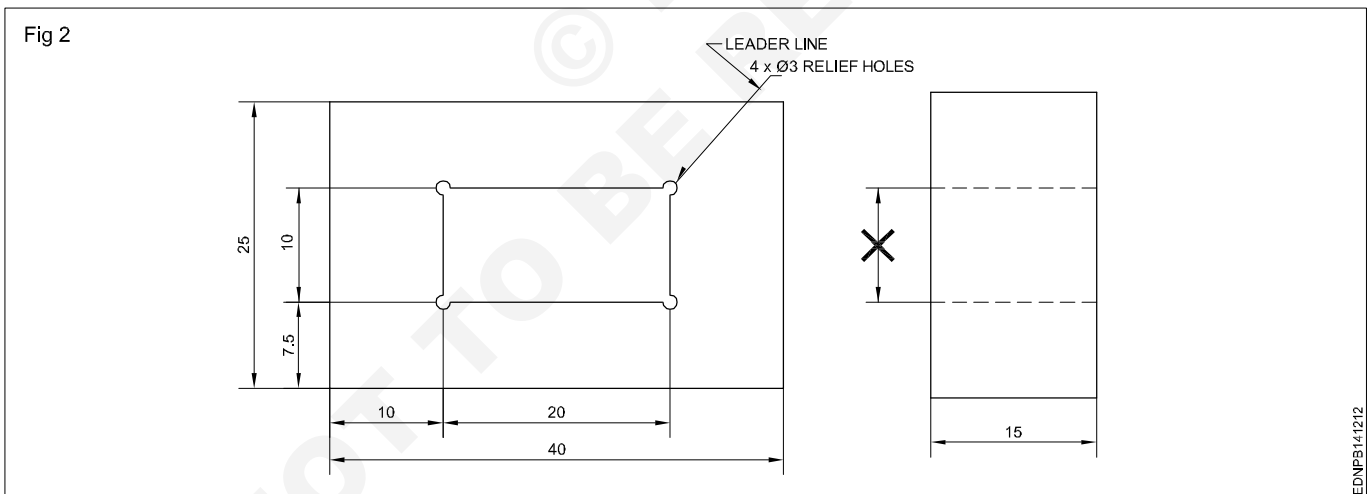

Arrowheads may be placed outside where space is insufficient.

Leader line: It is a thin continuous line. It connects a note or dimension with the features to which it applies. (Fig 2)

Termination and Origin indication: The size of the terminations (arrowheads/oblique strokes) shall be proportional to the size of the drawing. Only one style of arrowhead shall be used on a single drawing. However, where the space is too small for the arrowheads, it may be substituted by a dot or by an oblique line. Arrowheads are drawn as short lines forming barbs at any convenient

included angle between 15° and 90° . They may be open, closed or closed and filled in. Oblique strokes are drawn as short lines inclined at 45° . (Fig 1)

Indicating dimensional values on drawings: All dimensional values shall be shown on drawings in characters of sufficient size to ensure complete legibility on the original drawings as well as on reproductions made from micro-filming.

They shall be placed in such a way that they are not crossed or separated by any other line on the drawing.

Dimensioning - Position of dimensioning (aligned, unidirectional)

Definitions related to dimensioning

Dimension: It is a numerical value expressed as an appropriate unit of measurement and indicated graphically on technical drawings with lines, symbols and notes.

Dimensions are classified according to the following types:

Functional dimension (F): It is a dimension that is essential to the function of the component or space. They are generally shown with limits. (Fig 1)

Non-functional dimension (NF): It is a dimension that is not essential for the function of the component or space.

Auxiliary or Reference dimension (AUX/REF): It is the dimension given for information only. It is derived from the values given on the drawing or related documents and it will not be given for production or inspection. (Fig 1)

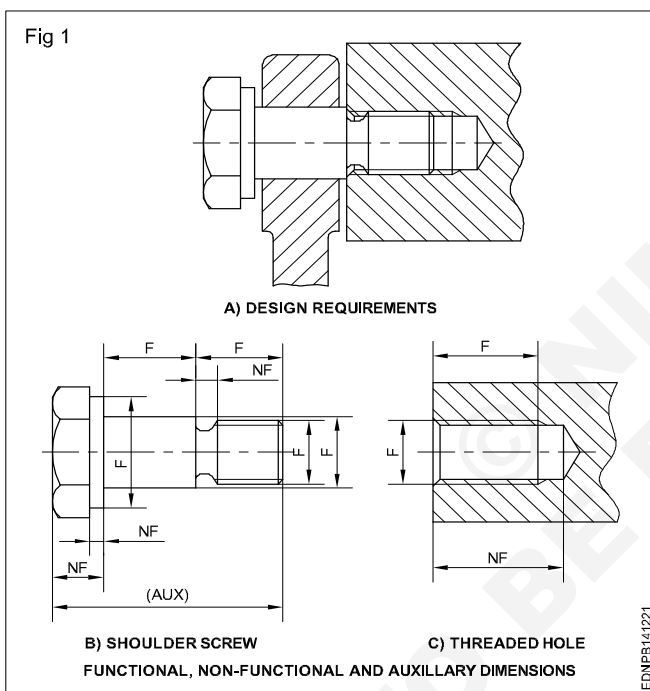

Methods of indicating values

Methods of indicating values: There are two methods used for indicating the values. Only one method should be used on any drawing.

Method 1 Aligned system

Dimensional values shall be placed parallel to their dimension lines and preferably near the middle, above and clear of the dimension line. However, values shall be indicated so that they can be read from the bottom of the drawing. Dimension lines should not be broken. Dimensioning of angles is also given in the same way. (Fig 1) This method is known as an **aligned system** of dimensioning.

Method 2 Unidirectional system

Dimensional values shall be indicated so that they can be read from the bottom of the drawing sheet. Non-horizontal dimension lines are interrupted, preferably near the middle

so that the value can be inserted. (Fig 2). This method is termed a **unidirectional system** of dimensioning.

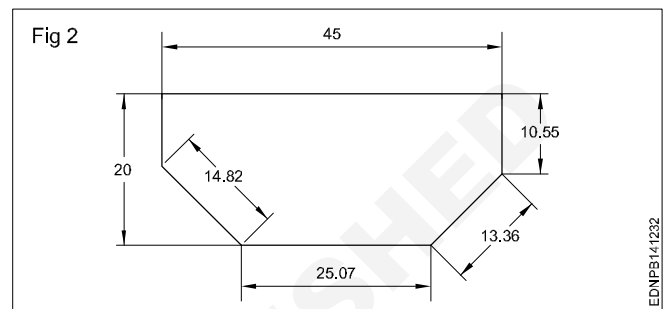
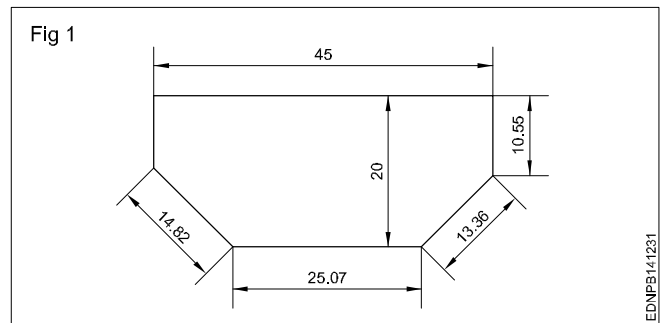

Chain dimensioning: It is used where the possible accumulation of tolerances does not infringe (effect) on the functional requirement of the component. (Fig 3)

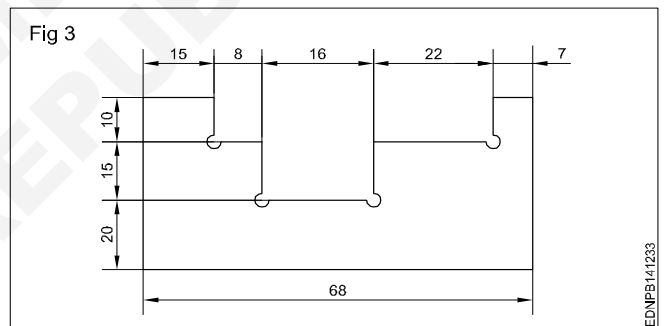

Dimensioning from a common feature is used where several dimensions of the same direction relate to a common origin.

Dimensioning from a common feature may be executed as parallel dimensioning or as superimposed running dimensioning.

Parallel dimensioning: Dimensions of features are taken from one datum/common origin and are shown parallel to another and placed so that the dimensional values can easily be added in Fig 4.

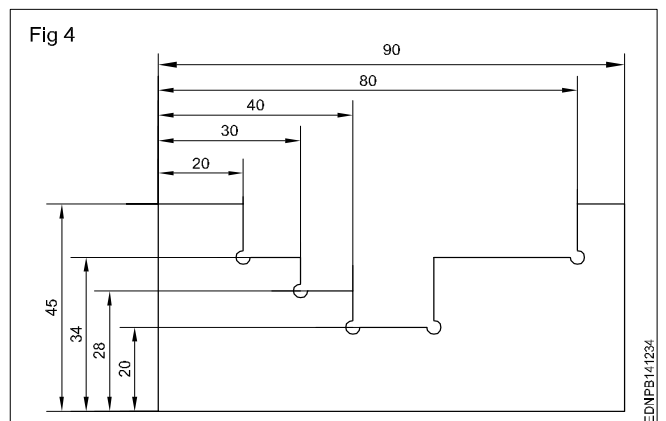

Combined dimensioning: Dimensions are given in chain dimensioning and parallel dimensioning. The common feature is combined. (Fig 5)

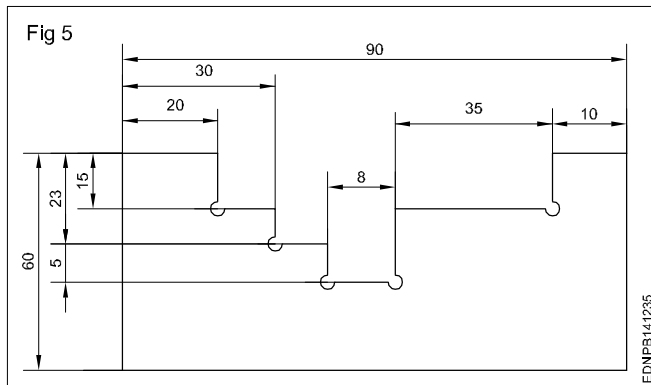

When the drawing is clear, symbols or abbreviation viz. dia, Pcd and angle can be omitted. (Fig 6)

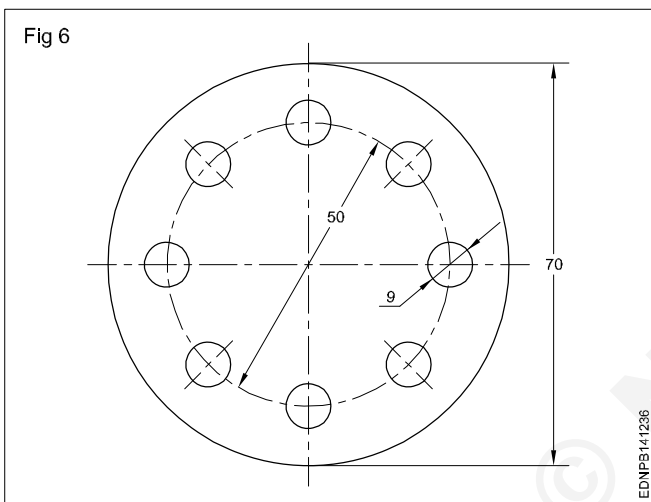

Dimensioning periphery: The features on the periphery can be shown as given in the figure, indicating width, depth and number of slots. (Fig 7)

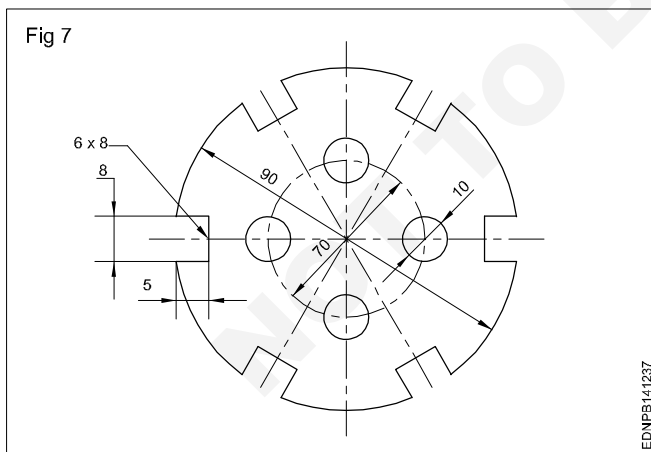

Countersinks and counterbore (IS:10968-1984): For simplification, the holes are indicated by centre lines and marked by different letters for different types/sizes of the hole. The holes may be plain, through the blind, tapped, countersink or counterbore. (Fig 8)

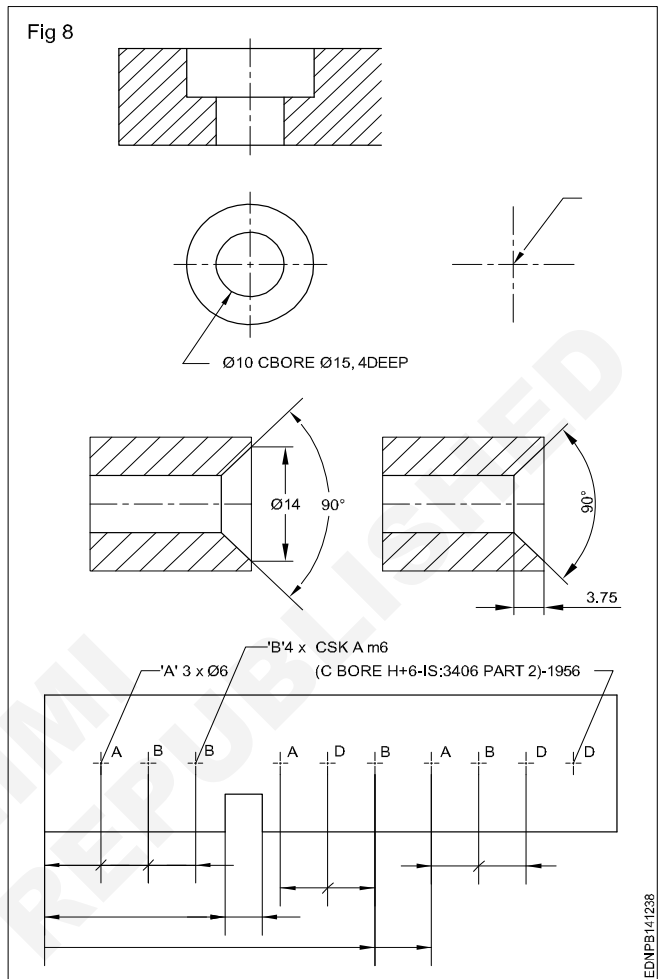

Dimensioning chamfers and undercuts: Chamfer of 45° may be shown by leader line indicating chamfer width and angle or by dimension line with chamfer width and angle. (Fig 9)

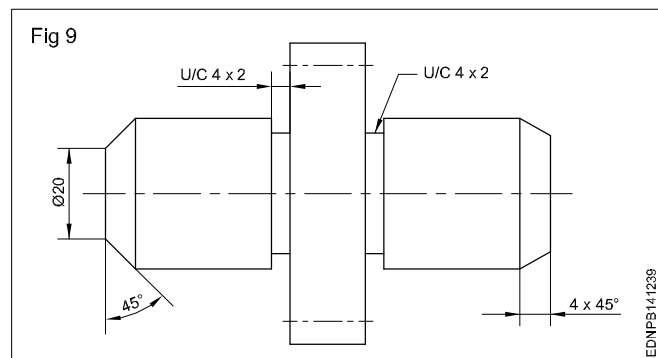

Practice of dimensioning

1 To the given drawing of the profile sheet metal as shown in Fig 1, place the dimensions in the aligned system. (Fig 1a)

- Draw the drawing of the sheet metal to 1:1 scale.
- Draw the extension lines in continuation of outlines.
- Draw the dimension lines. (Fig 1b)
- Place the dimension value near the middle and above the dimension line to be read from "bottom and right hand side" of the drawing.

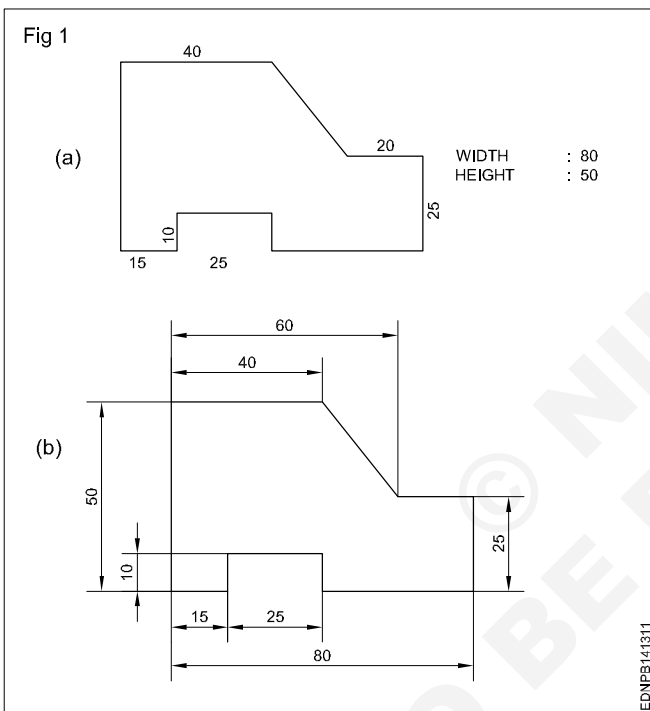

2 To the given drawing of the profile sheet metal as shown in Fig 2a, give the dimensions in the unidirectional system. (Fig 2b)

- Place the horizontal dimensions above and middle of the dimension line without break.
- Break the dimension in the middle of all non-horizontal dimension lines. (Fig 2b)

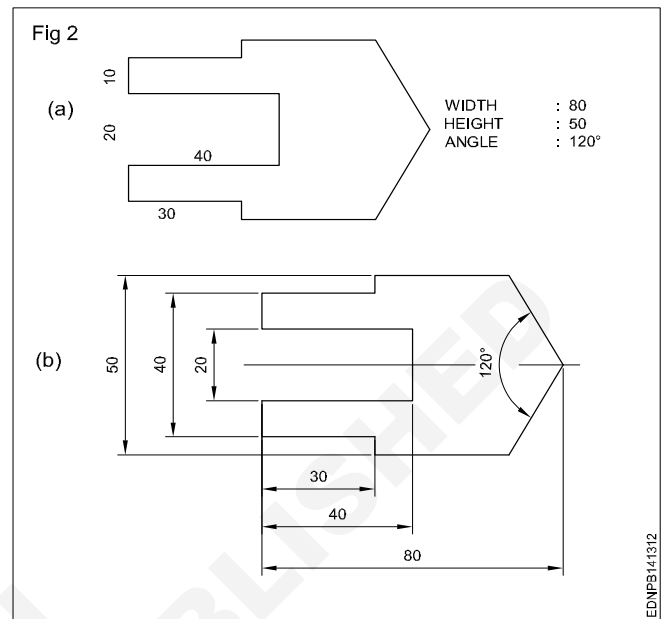

3 Draw the two sheet metal templates to full scale with appropriate lines use 0.5 range line thickness. (Fig 3)

- Draw a rectangular block of length 80 mm and width 50 mm in thin lines.
- Incorporate the features of the template as per the given dimension.
- Draw by thick lines all visible outlines.
- Give dimensions and maintain the line thickness as per the line range (0.5).
- Complete the figure and remove the unwanted lines.

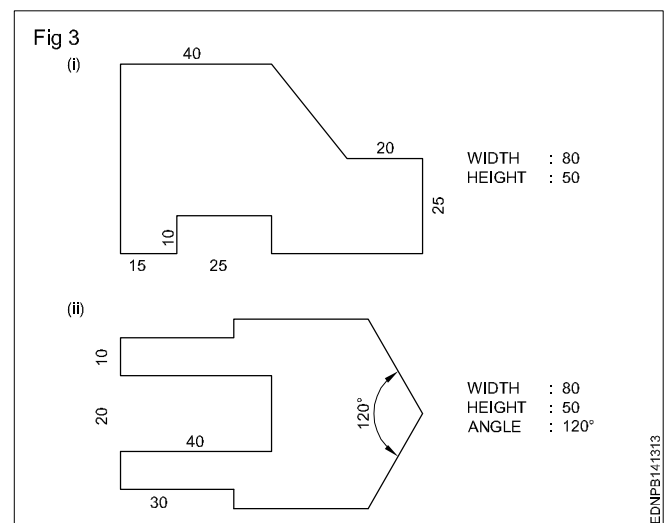

- 4 Draw the figures given. Maintain the types of lines as per the B.I.S and choose correct line thickness. (Fig 4)
- According to the given dimensions, draw the figures given in Fig 4.
 - Select the appropriate lines and maintain uniformity.
 - Remove (erase) unwanted lines, arcs and complete the drawing.

Note: Draw the dimension line terminations as per IS:11669-1986.

- 5 The motor cycle engine gasket is shown in figure 5. There are some mistakes in dimensioning. Reproduce the same in the A3/A4 sheet provided and correct the mistakes according to the aligned system of dimensioning. (Fig 5)

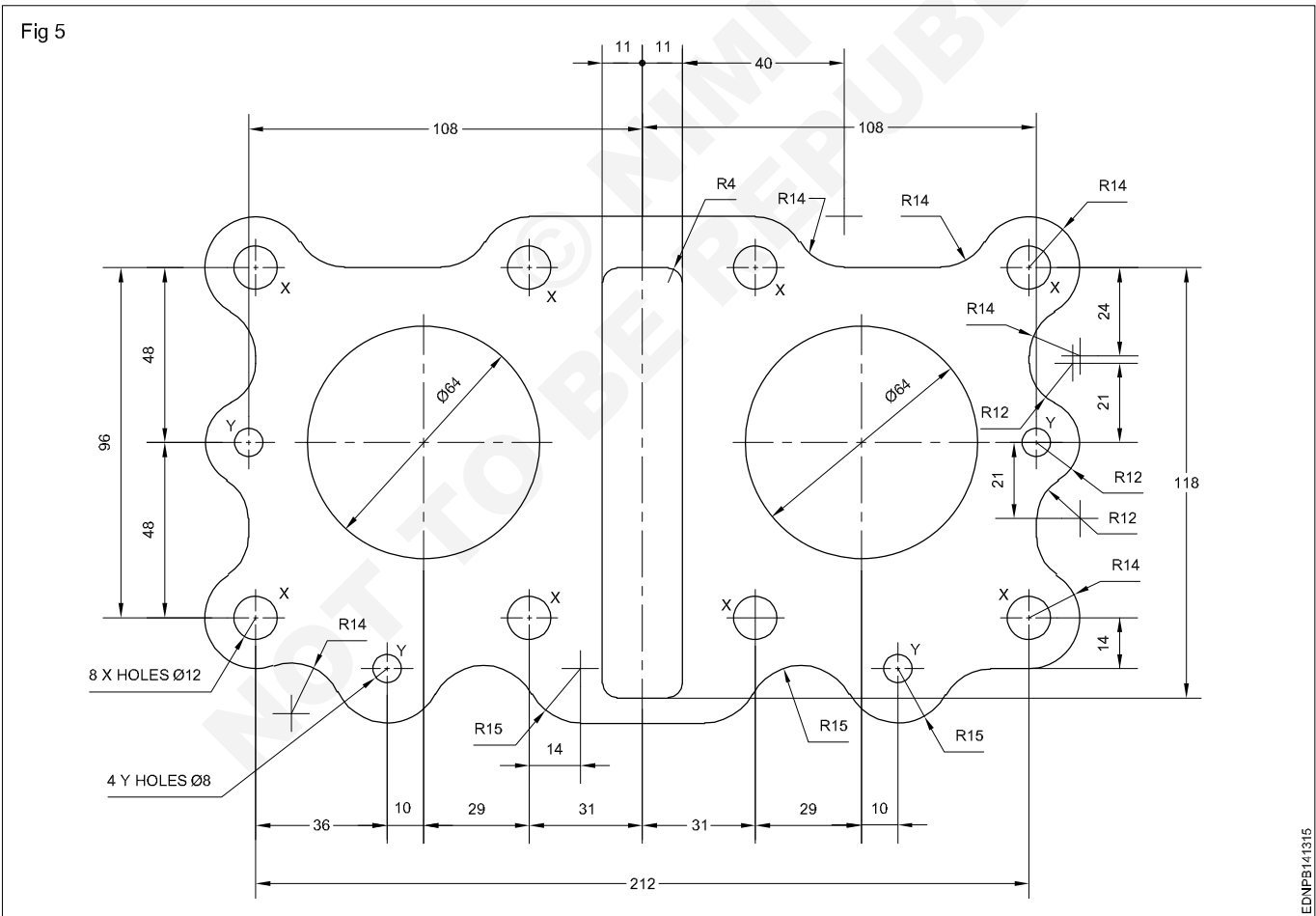
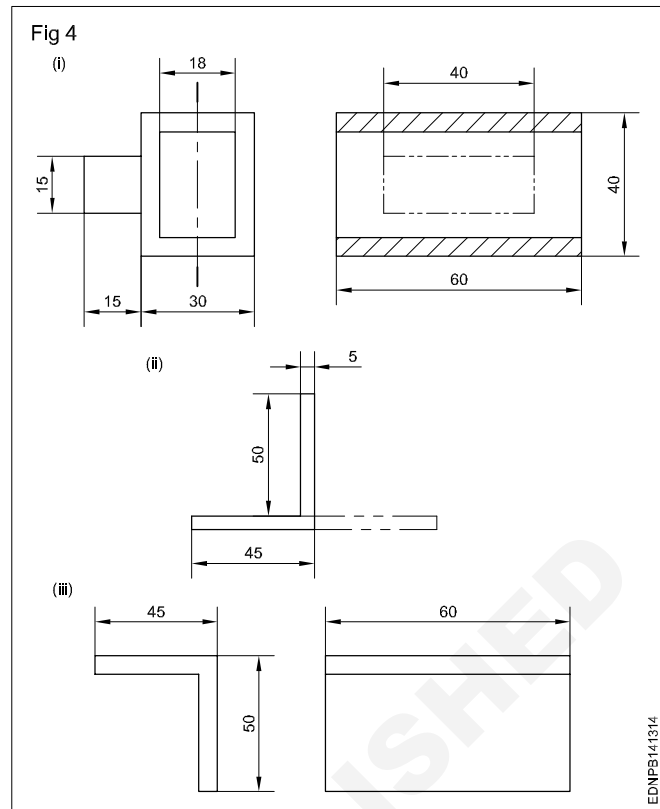

6 Draw the given cover plate and give the dimensions in the aligned system. (Fig 6)

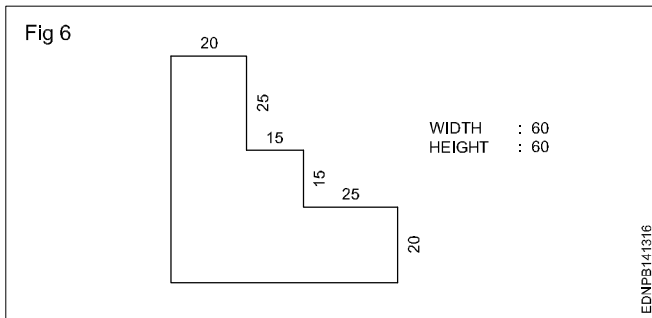



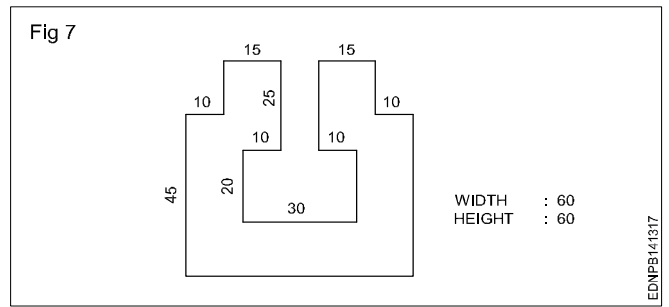





7 Draw the cover plate given in the figure and place the dimensions in the unidirectional system. (Fig 7)











© NIMI
NOT TO BE REPUBLISHED

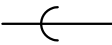
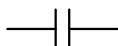
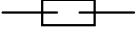
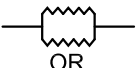

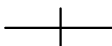

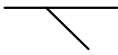
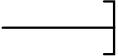
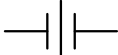
Symbolic representation - Different symbols

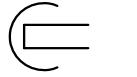
Sign and symbols for Plumber

S.No.	Description	Symbol
1	Bend 90°	
2	Bend 45°	
3	Turning/ down away	
4	Turning up/ towards	
5	Double branch	
6	Base	
7	Side outlet (Outlet down)	
8	Side outlet (Outlet up)	

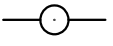
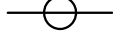
S.No.	Description	Symbol
9	Welded	 OR 
10	Soldered/ brazed	
11	Bell and spigot	
12	Flanged	
13	Flexible	 OR  OR 
14	Screwed (Plain coupling)	

S.No.	Description	Symbol
15	Lateral	
16	Cap	
17	Union	
18	Plug screwed	
19	Plug bell and spigot	
20	Reducer concentric	
21	Reducer eccentric	

S.No.	Description	Symbol
22	Straight size	
23	Outlet up	
24	Outlet down	
25	Single sweep	
26	Double sweep	
27	Cross	

Symbolic representation - Pipe joints used in the trade

Sign and symbols for Pipe joints











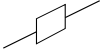
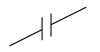
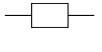
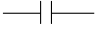

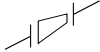
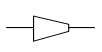

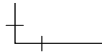

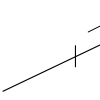
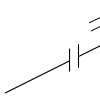

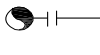
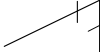

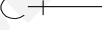
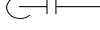

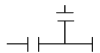

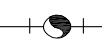
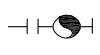

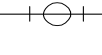
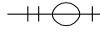

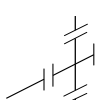
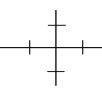
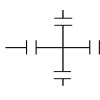
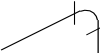
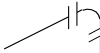
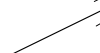

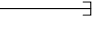
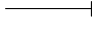
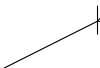
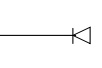
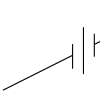

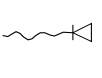

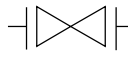

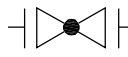
S. No.	Description	Isometric symbol (right face)		Orthographic symbol	
		Screwed	Flanged	Screwed	Flanged
1	Joint/Coupling				
2	Reducer				
3	90° elbow	---	---		
	(i) Turned up				
	(ii) Turned down				
4	Tee	---	---		
	(i) Turned up tee				
	(ii) Turned down tee				
5	Cross				
6	Bend			---	---
7	Plug (female)/(dead end)				
8	Plug (male)		---		---
9	Union		---		---
10	Hose nipple		---		---

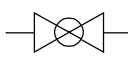
Image of Valves	Description	Buttweld Symbol	Flanged Symbol
	Gate		
	Globe		
	Ball		
	Plug		
	Butterfly		
	Needle		

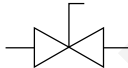
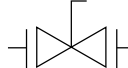
Representation of actual pipe joints used in the trade

G.I.Pipes

S.No.	Description	Symbol
1	Fit the 4 way cross to pipe No.2 and tighten it using a pipe wrench.	
2	Fit pipe No. 3 with the cross.	
3	Join the plain coupling to the other end of the pipe No. 3	
4	Fit the G.I bend to the plain coupling.	
5	Assemble the ribbed coupling to the other end of the G.I.bend	
6	Connect pipe No. 4 to the ribbed coupling	
7	Fit 'T' with pipe No. 4.	

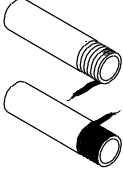
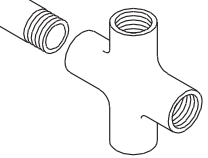
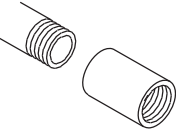
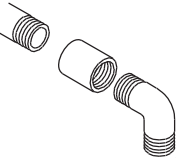
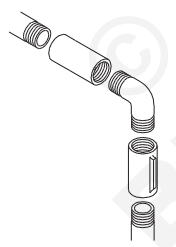
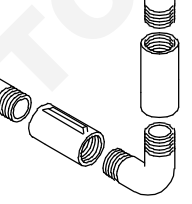
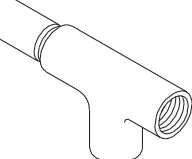
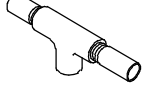
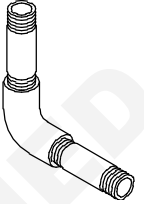
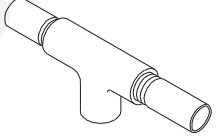
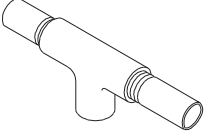
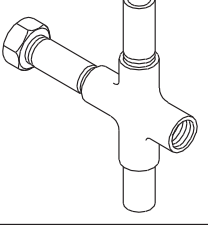
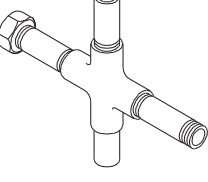
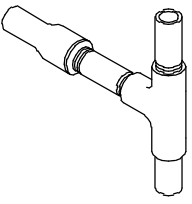
S.No.	Description	Symbol
8	Connect pipe No. 5 to the opposite end of 'T'	
9	Fit pipe No. 6 with the other end of the elbow	
10	Connect 'T' with pipe No. 6	
11	Fit pipe No. 1 with the opposite end of 'T'	
12	Fit a 150mm pipe nipple to the left side of the cross and put a cap for it	
13	Join another 150mm pipe nipple to the right side of the cross	
14	Connect the reducer to the pipe nipple	

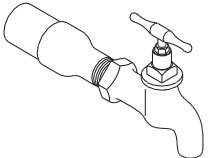
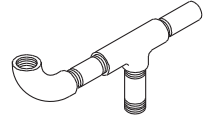
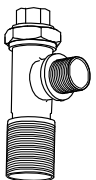
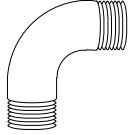
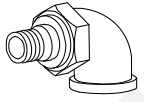
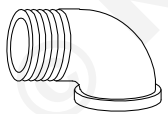
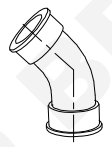
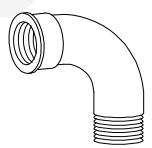
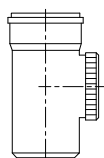
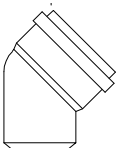

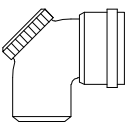
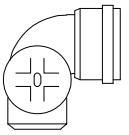
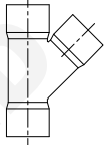
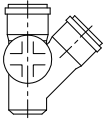
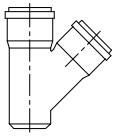
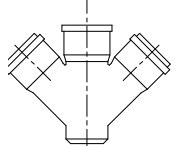
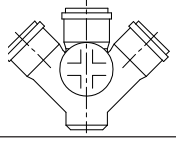
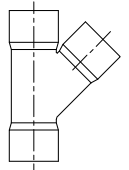
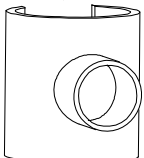
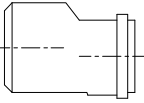

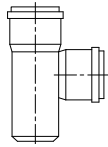
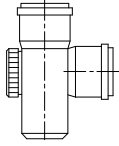
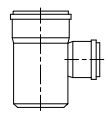
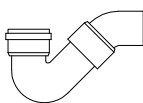
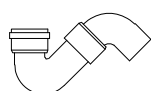
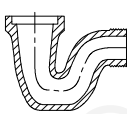
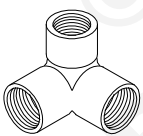
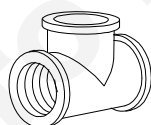
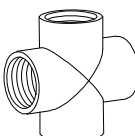
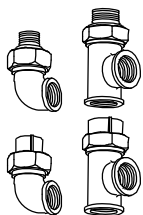
S.No.	Description	Symbol
15	Assemble a bib-cock to the other end of the reducer	
16	Fit a 100mm pipe nipple to the bottom side of 'T'	
17	Ferrule	
18	BEND	
19	Union elbow	
20	Elbow M+F	
21	Bend 45° (F+F)	
22	Bend (M+F)	
PVC sanitary fitting for soil waste and rainwater pipes		
23	Cleaning pipe	
24	Bend 45°	

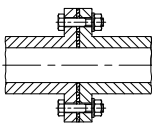
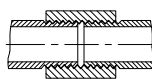
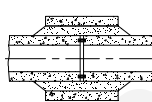
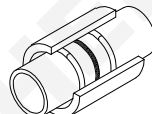
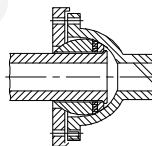
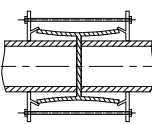
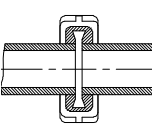
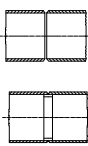
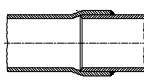
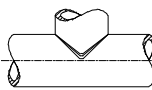
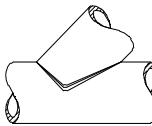
S.No.	Description	Symbol
25	Door bend	
26	Door bend RS/LS	
27	Single "Y"	
28	Single "Y" with door	
29	Reducing "Y"	
30	Double "Y"	
31	Double "Y" with door	
32	Single "Y" (S x S x S)	
33	Branch saddle	
34	Reducer eccentric	

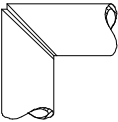
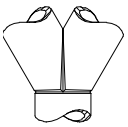
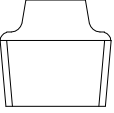
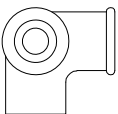
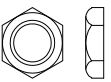
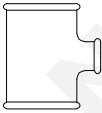
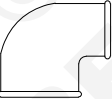
S.No.	Description	Symbol
35	Single "T"	
36	Single "T" with door	
37	Reducing "T"	
38	P trap	
39	Q trap	
40	Gully trap	
41	Three way elbow	
42	Tee (or) Three way	
43	Four way (or) cross	
44	Special union elbow and tee	

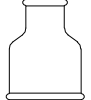
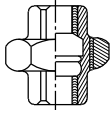
S.No.	Description	Symbol
45	Flanged joint	
46	Screwed joint	
47	Collar joint	
48	Joint for A.C pipes	
49	Flexiable joint	
50	Dresser coupling joint	
51	Victaulic joint	
52	Square butt joint with liner and without liner	
53	Bell and spigot joint.	
54	'Tee' joint	
55	Branch joints. 45°	

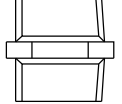
S.No.	Description	Symbol
56	'L' elbow joint	
57	'Y' joint.	
58	Plain plug	
59	Side outlet elbow	
60	Check nut	
61	Reducer tee	
62	Reducer elbow	

S.No.	Description	Symbol
63	Reducer socket	
64	Union	
65	Tee	
66	Cross tee	
67	Hexagon nipple	
68	Socket	
69	Elbow	

Reading of layout plan drawing in piping - Pipe fittings

Identify the pipe fittings, valves and cocks (Fig 1)

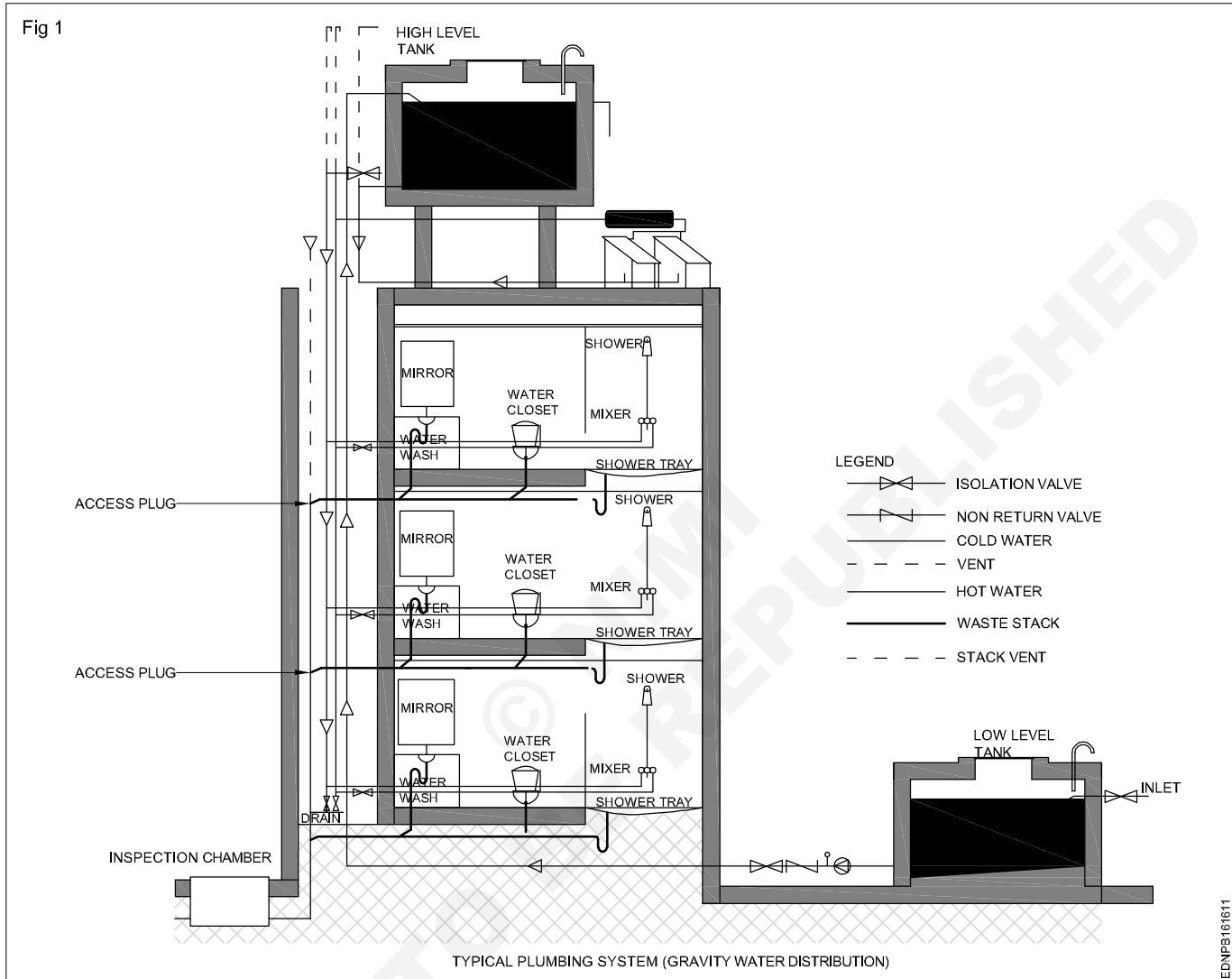

Read and write the following (Fig 1)

- 1 What is the function of isolation valve?
- 2 Why a non-return valve is required?
- 3 Why air vent is required?
- 4 What is the necessity of inspection chamber?
- 5 How water level is controlled?
- 6 What is the use of access plug?
- 7 Why the soil pipes are ventilated?
- 8 What is the use of traps in sanitary fittings?
- 9 How the waste water connections are connected?
- 10 Why the soil water connections are separately laid and connected directly to inspection chamber?
- 11 Which sanitary fittings are called unfoul fittings?
- 12 Which sanitary fittings used for hand washing?

Typical plumbing system (Pressurized distribution) (Fig 2)

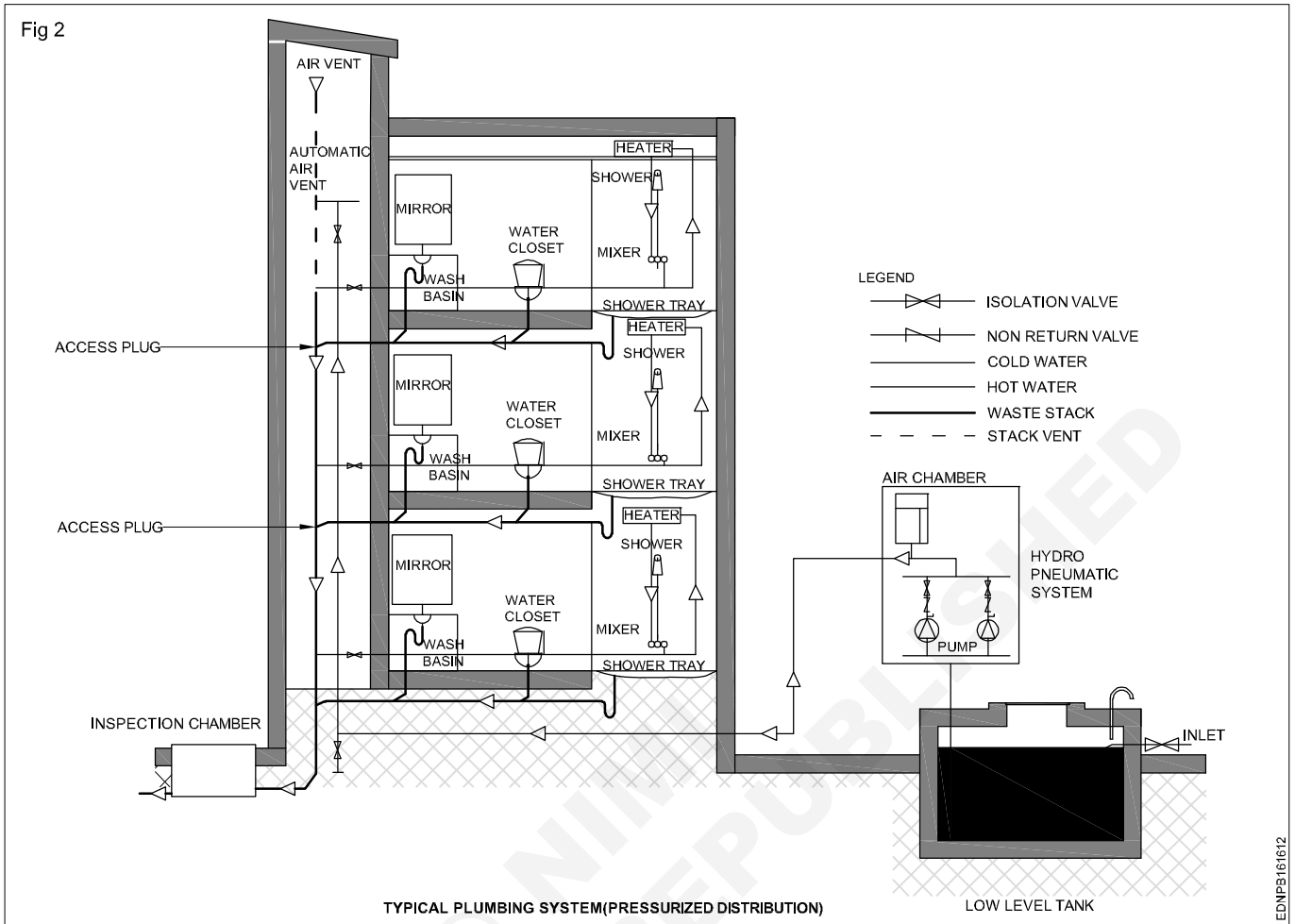

EDNP3161612

Read and write the following (Fig 2)

- 1 What is the function of Air chamber?
- 2 What is the difference between gravity water distribution and pressurized water distribution?
- 3 Where pressurized water distribution is required?
- 4 How equal water pressure in various places is maintained?
- 5 What is the advantages of pressurised water distribution system?
- 6 What is the use of low level tank?
- 7 Why slope (or) gradient is given to the soil and waste water line?
- 8 Why glazing is provided in the sanitary fittings?
- 9 What will happen if sanitary traps are not provided?
- 10 What is the use of mixing taps?
- 11 Which sanitary fittings is used for cleaning utensils?
- 12 Why drain board is provided in the kitchen sinks?

Simple water supply pipe line connection (Fig 3)

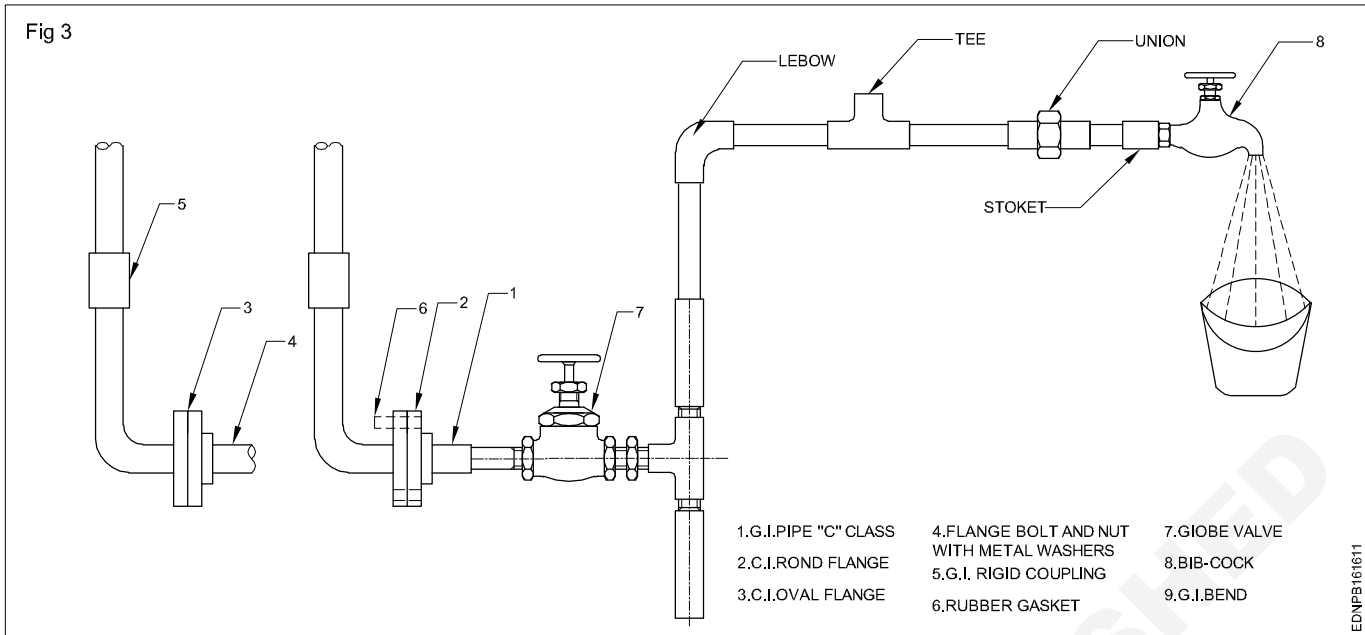

Read and write the following (Fig 3)

- 1 Why union is fixed in the pipe layout?
- 2 Which fitting is used to connect two same dia pipes?
- 3 Which fitting is used to take branches from pipe line?
- 4 Which fitting is used for 90 degree changes in the direction in pipe line connections?
- 5 What is the name of the fitting used to connect two female threaded fitting?
- 6 What is the main advantage of flanges providing in the pipe line connections?
- 7 What is the name of threads provided in pipes?
- 8 Which is kept between two flanges to arrest water leakage?
- 9 How many threads to be tightened to the fittings normally?
- 10 Why pipe fittings should not be over tightened?
- 11 What is the purpose of valves in the pipe line connection?
- 12 Where the Bib cock are provided in the pipe line?
- 13 What is the colour indication for 'C' class pipes?
- 14 What is the main difference between elbow and bend?
- 15 What is the name of the coating provided in the G.I pipe?

Layout of PVC pipe drawing (Fig 4)

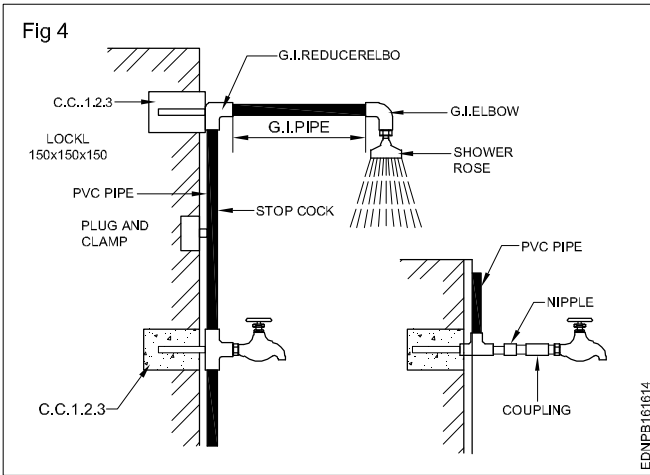

Read and write the following (Fig 4)

- 1 What is the name of fitting used to control water?
- 2 What is the minimum height of shower arm to be fixed from FFL?
- 3 What is the name of fitting used to draw water?
- 4 Which fitting is used for overhead shower?
- 5 Which fitting is fixed in tee (or) elbow to extend the distance?
- 6 What is the name of fitting used to connect small dia pipe to bigger dia pipe in straight pipe line?
- 7 What is the name of adhesive used to join P.V.C pipe?
- 8 Which type of P.V.C pipe is used for both hot and cold water connection?
- 9 Which P.V.C pipe can be threaded as well as pasted?
- 10 Which hot water P.V.C pipe cannot be threaded?

Layout of simple pipe line connection (Fig 5)

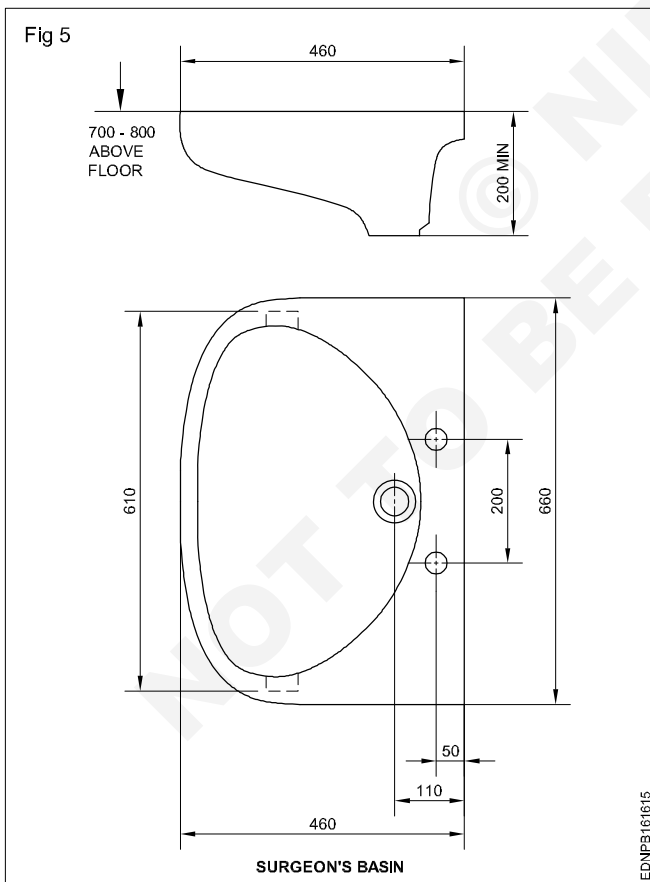

Read and write the following (Fig 5)

- 1 What is the name of tool used to tighten the fittings?
- 2 What is the name of equipment used to hold the pipe?
- 3 What is the name of tool used to cut pipe quickly?
- 4 What is the name of tool used to measure longer distances?
- 5 What is name of fitting if measurement have both ends threaded of below 12 inches??

Layout of water distribution pipe line (Fig 6)

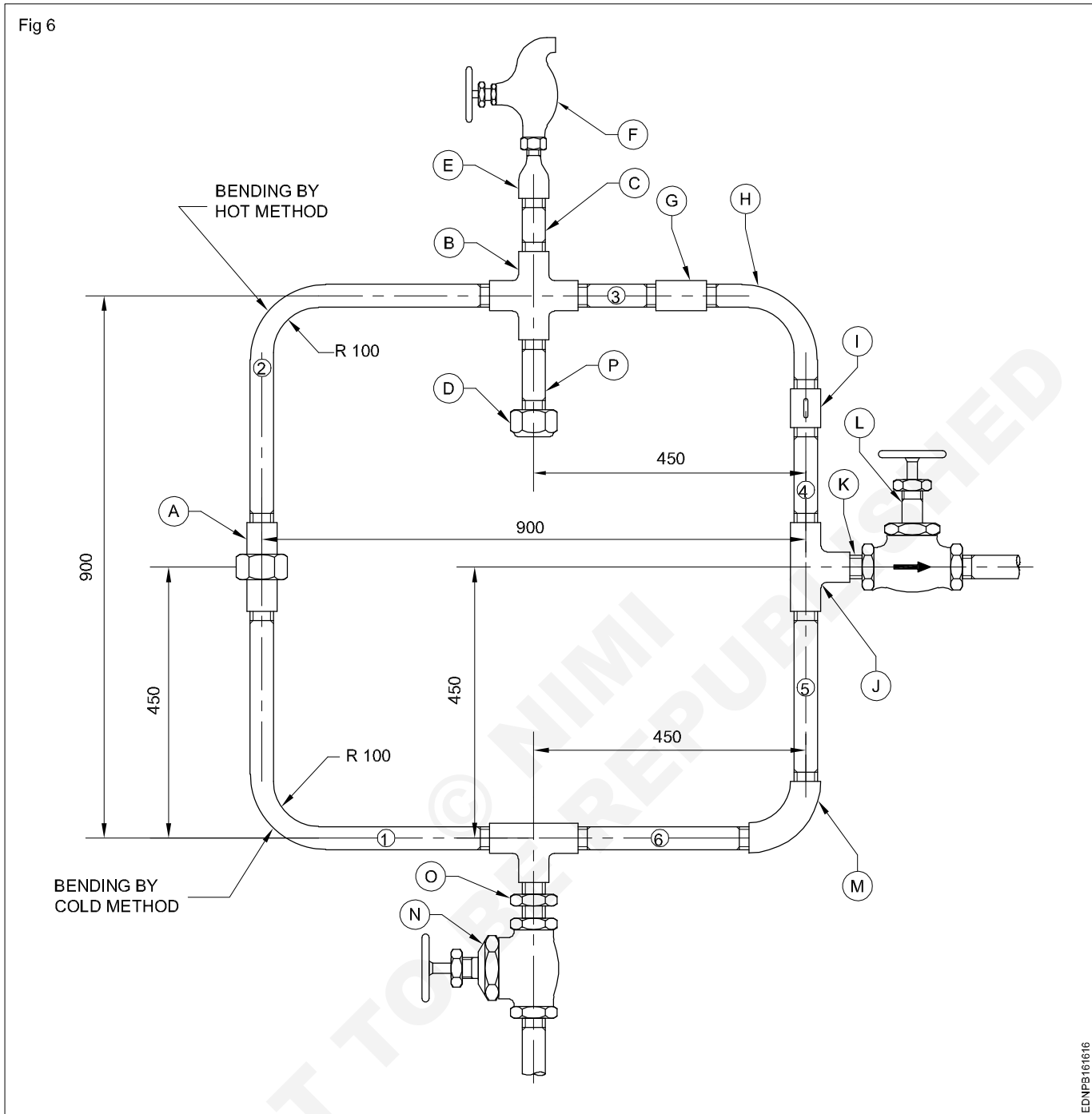

Read and write the following (Fig 6)

- 1 What is the name of fitting D and P?
- 2 What is the name of fitting F, L & N?
- 3 What does the letter E, B and G stands for?
- 4 What is the name of letter G and J stands for?
- 5 What is the name of fitting A and J in figure?
- 6 What does the letter C, H and M stands for?
- 7 What is the length between A and J?
- 8 What is the name of coating provided for stain proof in Bib cock?
- 9 Why step is given in letter 'I' fitting?

Reading of layout plan drawing in piping - Sanitary fittings

Identify the soil pipes, waste water pipe, airvent pipe (Fig 1 & 2)

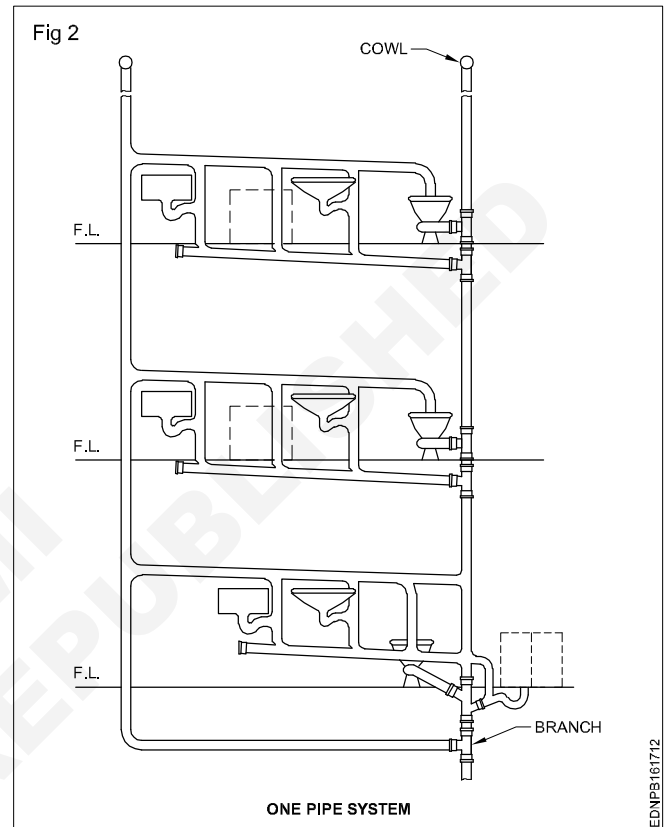
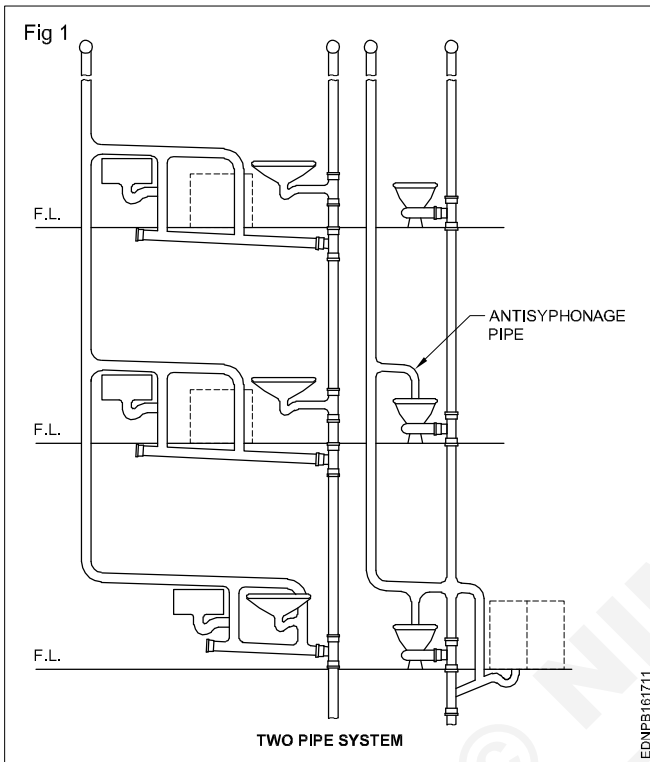

Read and write the following (Fig 1 & 2)

- 1 What is the name of plumbing system given in Fig 1?
- 2 Which pipe arrangement protect the water seal in trap?
- 3 What will happen if ventilation is not provided in system?
- 4 What is the name of fitting used to cover the V P?
- 5 What is the name of plumbing system given in Fig 2?
- 6 Which fitting is provided for foul and unfoul fittings in one pipe system?

Sanitary fittings (Fig 3)

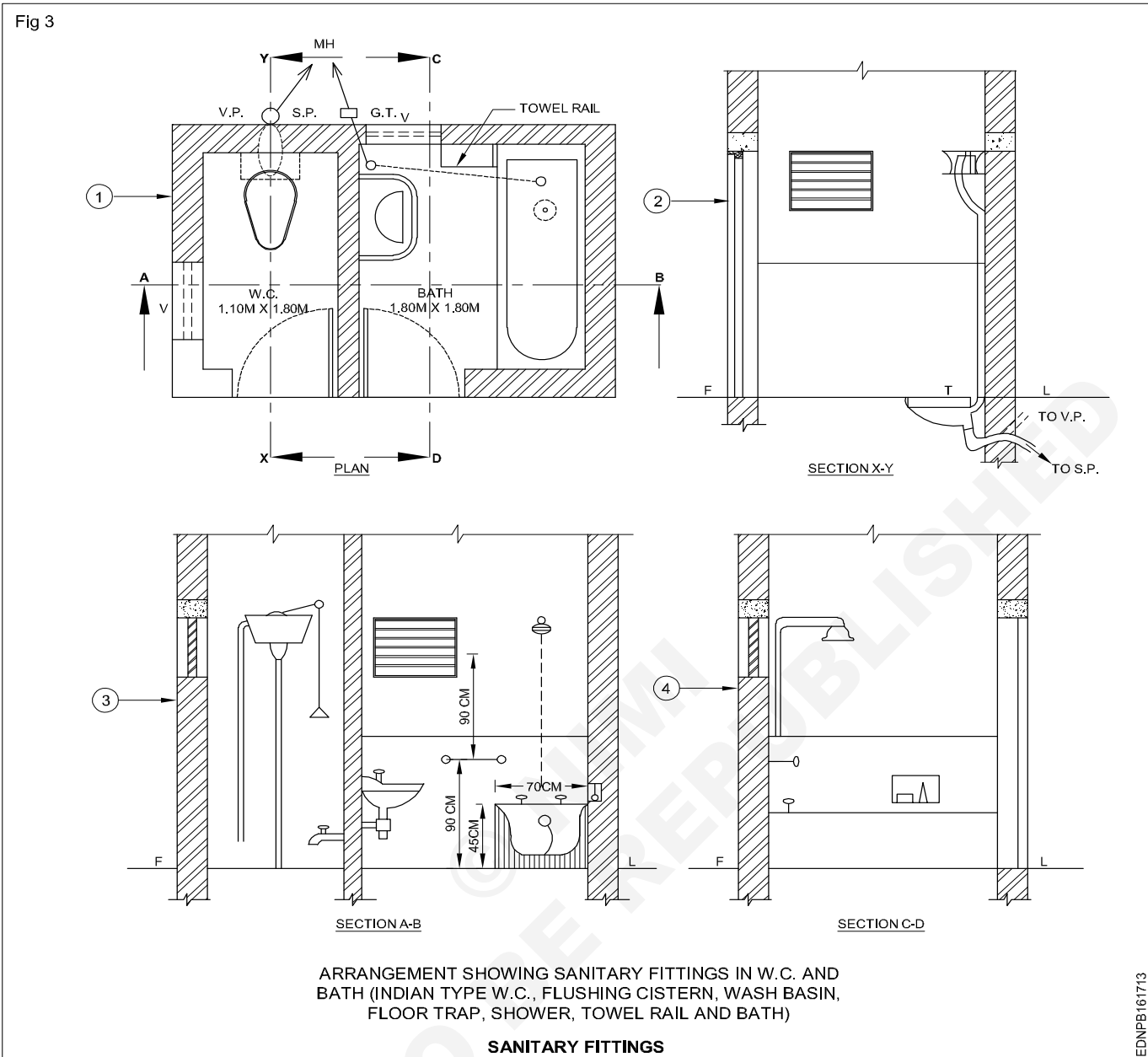

Read and write the following (Fig 3)

- 1 What are the sanitary fittings installed in Fig 3?
- 2 Which fitting discharge unfoul water given in Fig 3?
- 3 Which abluition fitting is used for bathing?
- 4 Which abluition fitting is used for hand face washing?
- 5 Which fitting is called as soil fitting?
- 6 What is meant by V.P?
- 7 What is the meaning of S.P?
- 8 What does F.P stands for?
- 9 Why F.P is connected to I.W.C?
- 10 What is the name of sanitary fitting used to clean the I.W.C?
- 11 Which material H.L.F.C is made off?
- 12 What is the capacity of H.L.F.C?
- 13 What is the height of wash basin from FFL?
- 14 What is the height of H.L.F.C from FFL?
- 15 What is the height of L.L.F.C top point from FFL?
- 16 What is the height of shower Doom from FFL?
- 17 What is the name of material which protect stain in the bath fittings?
- 18 What is the name of process gives smooth finish in the sanitary appliances?
- 19 Why glazing is provided in the sanitary fittings?
- 20 Why should not be glazed the portion underneath the ground?
- 21 Which material doom is made of in flushing cistern?
- 22 Which fitting is used to maintain water level in flushing cistern?
- 23 What is the name of action takes place while pressing the handle in flushing cistern?

A public lavatory (Fig 4)

Fig 4

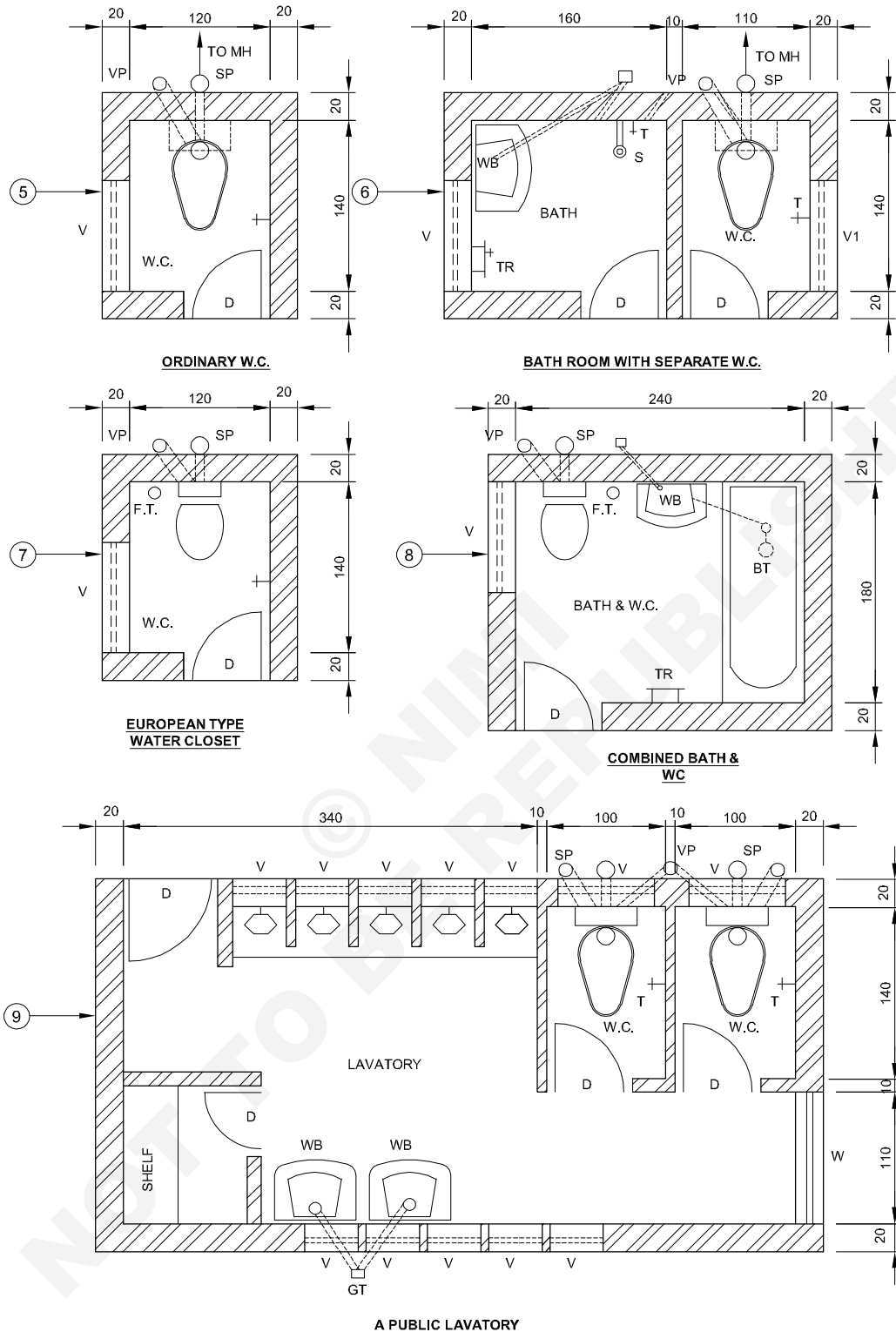

NOTE:-

S.P. - SOIL PIPE	V.P. - VENT PIPE
M.H. - MAN HOLE	W.C. - WATER CLOSET
FT - FLOOR TRAP	WB - WASH BASIN
T.R. - TOWEL RAIL	T - TAP
GT - GULLY TRAP	BT - BATH TUB

ALL DIMENSIONS ARE IN CENTIMETERS

A PUBLIC LAVATORY

EDNPB161714

Read and write the following (Fig 4)

- 1 What is the size of I.W.C block?
- 2 Why traps are provided in I.W.C?
- 3 What are the traps provided in I.W.C?
- 4 Which material is used to make 'S' trap and 'P' trap?
- 5 What is the name of curved area?
- 6 What is the rectangular section meant for?
- 7 What is the T.R meant for?
- 8 What is the name of tap provided in the wash basin?
- 9 What is the name of fitting fixed for waste outlet in WB?
- 10 What is the expansion for L.L.F.C?
- 11 What is the capacity of the L.L.F.C?
- 12 What is the material used to manufacture L.L.F.C?
- 13 What is the height of L.L.F.C bottom from EWC pan?
- 14 What is the expansion for B.T, W.C?
- 15 What is the expansion for E.W.C?
- 16 Which fitting is used to connect range of I.W.C outlet?
- 17 What is the expansion for S.P.F?
- 18 What is the name of trap provided to WB?
- 19 What is the name of waste trap used to connect more than one connection?

Reading of layout plan drawing in pipe accessory (Fig 5)

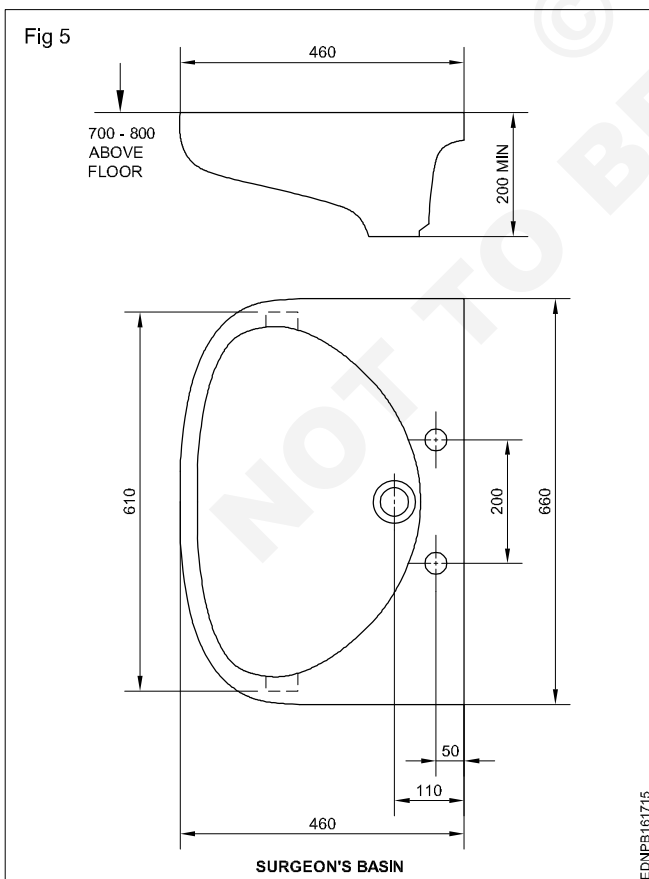

Read and write the following (Fig 5)

- 1 What is the name of the sanitary fitting given in Fig 5?
- 2 What is the purpose of wash basin?
- 3 What is the height of toilet paper holder from FFL?
- 4 What is the name of coating provided in WB?

Integrated squatting pan and Orissa pattern (Fig 6 & 7)

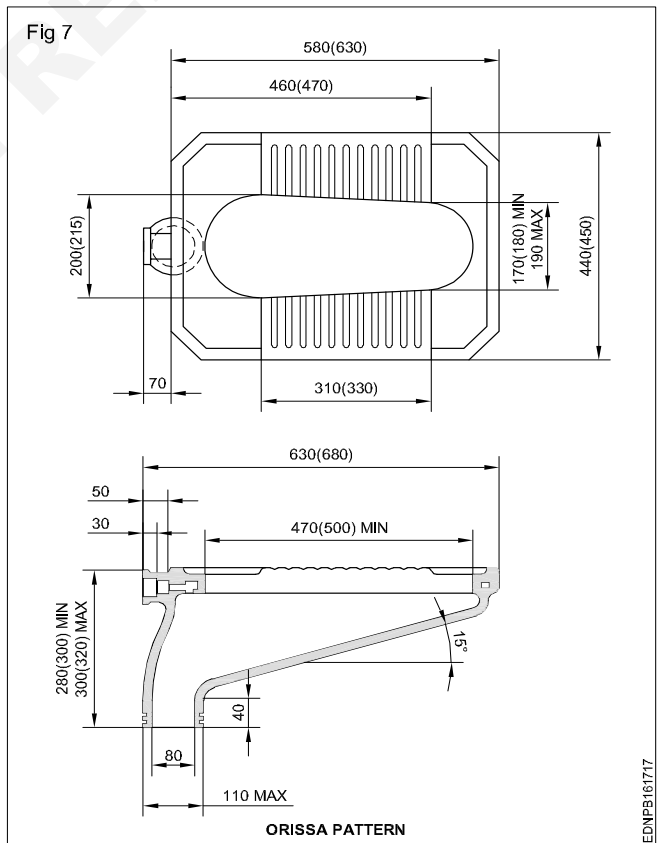
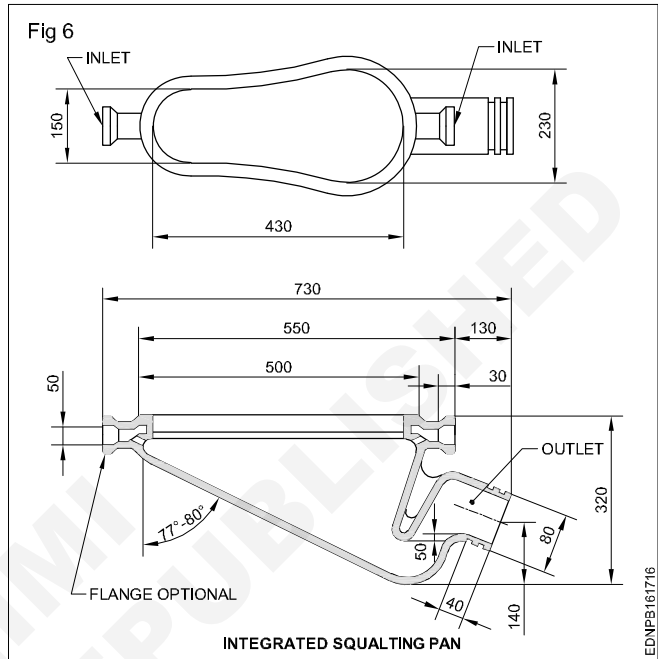

Read and write the following (Fig 6 & 7)

- 1 What is the name of sanitary fitting given in Fig 6?
- 2 What is the name of sanitary appliance given in Fig 7?
- 3 Which material is used for manufacturing sanitary fittings?
- 4 What is the name of process to give smooth finish in sanitary fittings?
- 5 Why traps are provided in sanitary fittings?

S Trap (Fig 8)

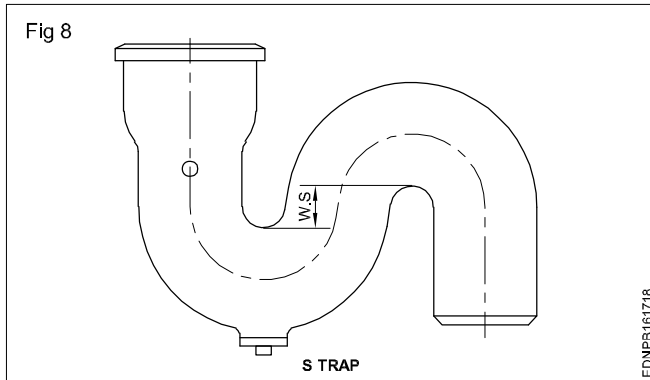

Q Trap (Fig 9)

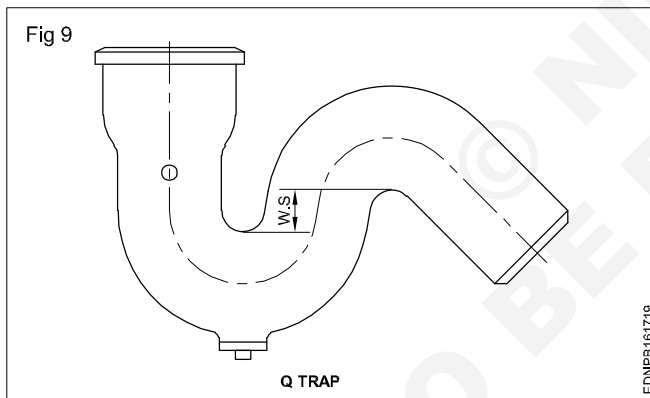

Floor Trap (Fig 10)

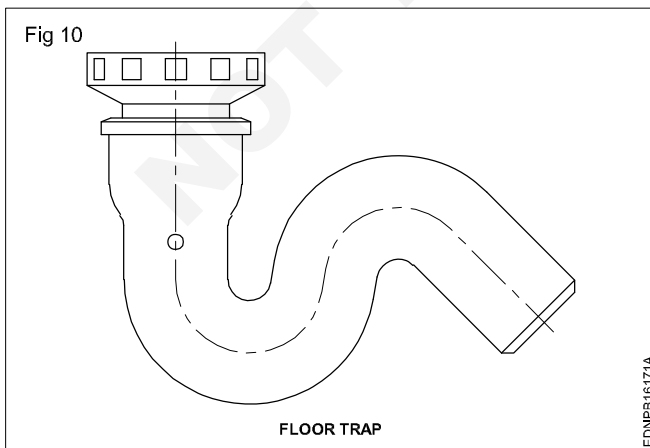

Read and write the following (Fig 8 to 10)

- 1 What is the name of fitting given in Fig 8?
- 2 What is the name of sanitary fitting given in Fig 9?
- 3 What is the name of fitting given in Fig 10?
- 4 Why water seal is provided in the traps?
- 5 Why traps are used in the sanitary fittings?

Ranges of urinals (Fig 11)

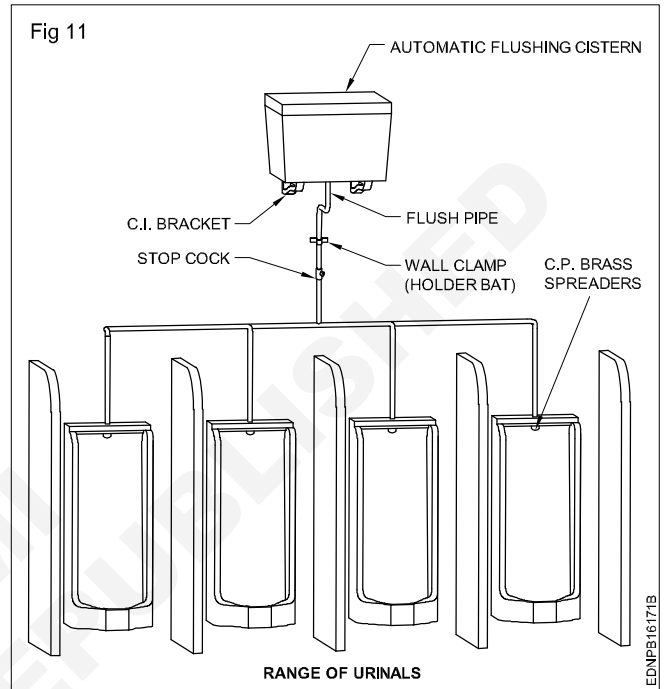

Installation of urinal (Fig 12)

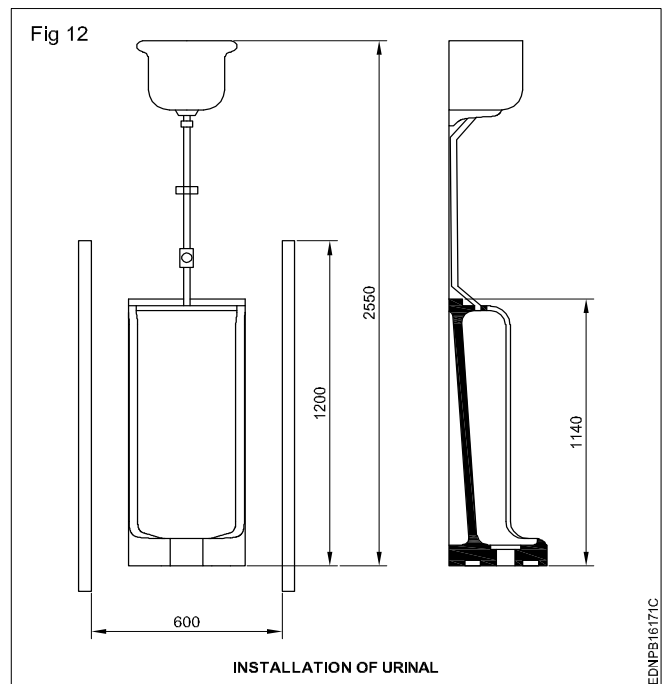

Bath tub (Fig 13 & 14)

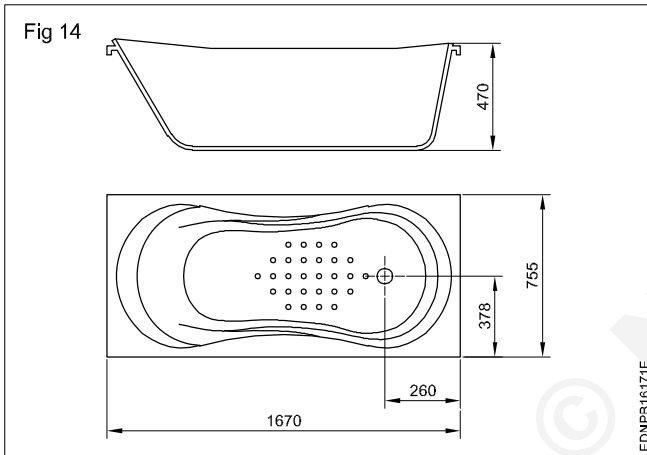
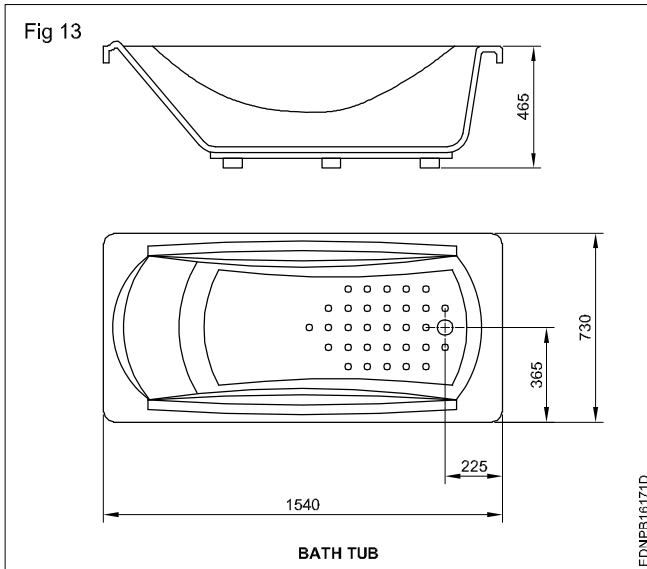

Read and write the following (Fig 11 to 14)

- 1 What is the name of arrangements given in Fig 13?
- 2 What is the name of F.T fixed for range of urinals?
- 3 What is the name of fittings used in clean stall urinal?
- 4 What is the name of fitting used in hold F.T?
- 5 What is the minimum capacity of automatic F.T?
- 6 What is the purpose of BT?
- 7 What is the height of bathtub?
- 8 What is the name of fitting used to cover the outlet in BT?

Sensor urinal (Fig 15)

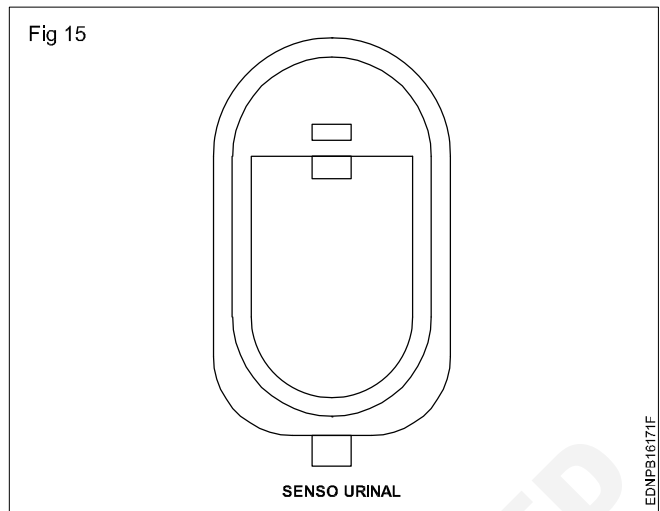

Waterless urinal (Fig 16)

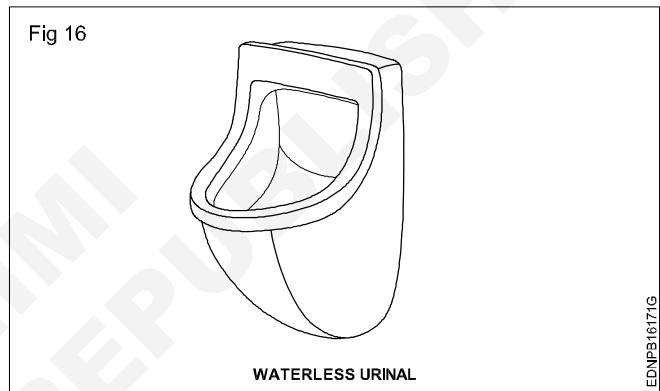

Flat back urinal (Fig 17)

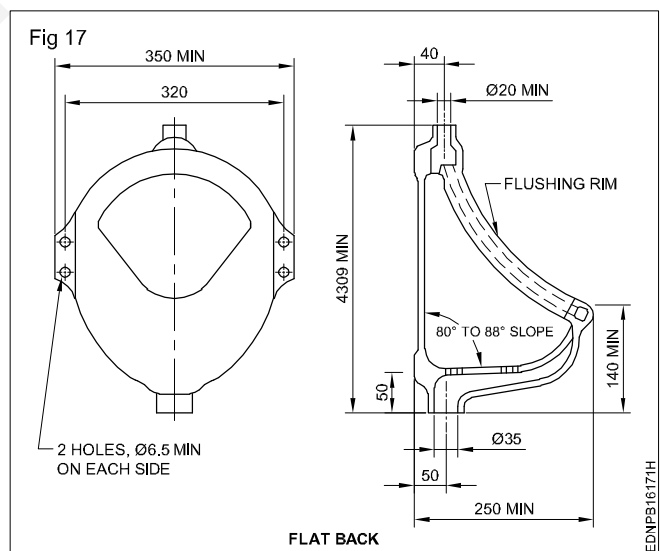

Angle back urinal (Fig 18)

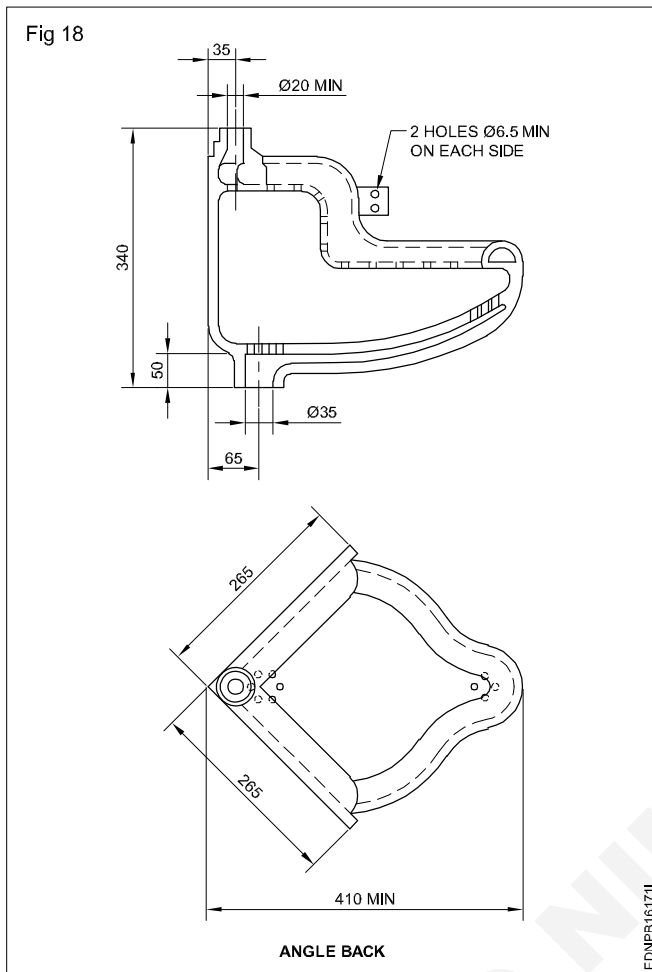

Urinal-Stall (Fig 19)

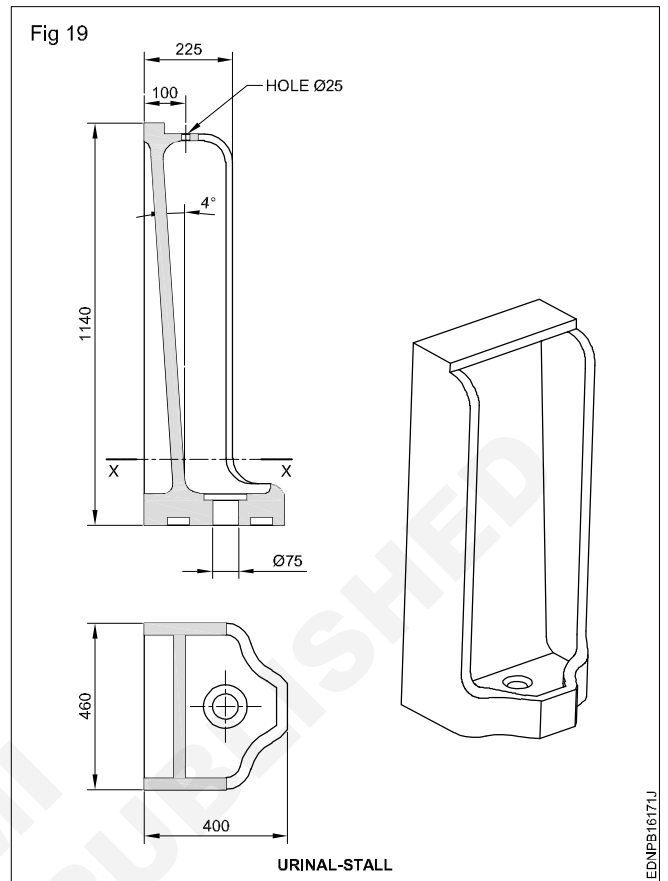

Read and write the following (Fig 15 to 19)

- 1 What is the advantage of sensor urinal?
- 2 What is the advantage of waterless urinal?
- 3 What is the name of fitting given in Fig 18?
- 4 What is the name of sanitary fitting given in Fig 19?
- 5 What is the name of fitting given in Fig 15?